

Dinosaurs reveal the geographical signature of an evolutionary radiation

Article

Accepted Version

O'Donovan, C., Meade, A. ORCID: <https://orcid.org/0000-0001-7095-7711> and Venditti, C. ORCID: <https://orcid.org/0000-0002-6776-2355> (2018) Dinosaurs reveal the geographical signature of an evolutionary radiation. *Nature Ecology & Evolution*, 2 (3). pp. 452-458. ISSN 2397-334X doi: 10.1038/s41559-017-0454-6 Available at <https://reading-pure-test.eprints-hosting.org/75344/>

It is advisable to refer to the publisher's version if you intend to cite from the work. See [Guidance on citing](#).

Published version at: <http://dx.doi.org/10.1038/s41559-017-0454-6>

To link to this article DOI: <http://dx.doi.org/10.1038/s41559-017-0454-6>

Publisher: Nature

All outputs in CentAUR are protected by Intellectual Property Rights law, including copyright law. Copyright and IPR is retained by the creators or other copyright holders. Terms and conditions for use of this material are defined in the [End User Agreement](#).

www.reading.ac.uk/centaur

CentAUR

Central Archive at the University of Reading

Reading's research outputs online

1 **Dinosaurs reveal the geographic signature of an evolutionary radiation**

2

3 **Ciara O'Donovan¹, Andrew Meade¹ and Chris Venditti^{1*}**

4 ¹ School of Biological Sciences, University of Reading, Reading RG6 6BX, UK

5 * Correspondence to c.d.venditti@reading.ac.uk

6

7

8

9

10

11

12

13

14

15

16

17

18

19

20

21 **Dinosaurs dominated terrestrial ecosystems across the globe for over 100 million years**
22 **and provide a classic example of an evolutionary radiation. However, little is known**
23 **about how these animals radiated geographically to become globally distributed. Here,**
24 **we use a biogeographical model to reconstruct the dinosaurs' ancestral locations,**
25 **revealing the spatial mechanisms that underpinned this 170 million years long**
26 **radiation. We find that dinosaurs spread rapidly initially followed by a significant**
27 **continuous and gradual reduction in their speed of movement towards the Cretaceous-**
28 **Tertiary (K/Pg) boundary (66mya). In addition, this suggests that the predominant mode**
29 **of dinosaur speciation changed through time with speciation originally largely driven**
30 **by geographic isolation – when dinosaurs speciated more they moved further. This was**
31 **gradually replaced by increasing levels of sympatric speciation (species taking**
32 **advantage of ecological opportunities within their existing environment) as terrestrial**
33 **space became a limiting factor. Our results provide the first view of the geographic**
34 **signature of an evolutionary radiation.**

35 From a single, modest ancestor that existed over 230 million years ago at the
36 beginning of the Mesozoic (an era which spans from 252 – 66 mya) the dinosaurs evolved
37 into a group that was morphologically and ecologically diverse as well as speciose¹⁻³. During
38 this time dinosaurs spread geographically and are now known for their dominance of terrestrial
39 environments⁴ across the entire globe. Given that the earliest known dinosaur fossils are from
40 rocks now in South America dating from the early-Late Triassic⁵ (approximately 231 million
41 years ago) it is often assumed that this is where the ancestor of all dinosaurs existed^{6,7}.
42 Despite there being thousands of later dinosaur fossils littered across the globe, the limited
43 insight into the locations of intermediate species means that we cannot determine how
44 dinosaurs came to be so far away from their origin. As a result, descriptions of raw fossil
45 locations paint a limited picture of dinosaur biogeography. To uncover how the dinosaurs
46 spread to every corner of the Earth a different approach is needed.

47 We introduce a Bayesian statistical method to reconstruct the ancestral locations of
48 the dinosaurs in a comprehensive phylogenetic tree⁸ to fill in the gaps in the fossil record and
49 uncover the dinosaurs' paths across the globe. We do this in continuous, three dimensional
50 space⁹ using all of the available fossil occurrence data describing the dinosaurs' locations -
51 including multiple locations for individual taxa (see Methods). Our model allows us to detect
52 significant increases or decreases in the speed of dinosaur movement without any prior
53 information about the temporal or phylogenetic position of such shifts having based our
54 geographical model on the variable rates model of Venditti *et al.*¹⁰. This means that unlike any
55 previous biogeographical study, we can determine the *distance moved* (we use this term and
56 its derivations to describe the movement of species rather than of individuals or populations),
57 speed and direction of movement along each branch of the phylogenetic tree (see Methods).

58

59 Results and Discussion

60 Using our estimates of ancestral locations we can describe the intermediate steps that
61 resulted in the dinosaur species that we have fossil evidence of today thus making our view
62 of the dinosaur radiation more complete than was previously possible with fossil locations
63 alone. We reconstruct the ancestor of all dinosaurs to be within the landmass that is now South
64 America which corroborates the common assumption based on the early dinosaur fossil
65 record^{6,7}. A sample of dispersal paths taken by six species is shown in Figure 1. These
66 illustrate the diversity of routes taken across the globe, even by dinosaurs which ended up in
67 the same location (Figure 1 c and f) and show a pattern whereby ancestral nodes mostly
68 cluster together but with a descendant occasionally moving far away from its predecessors.
69 This pattern of movement is universal amongst the dinosaurs and hence their expansion can
70 be said to be characterised by a mixture of mostly short distance, local movements
71 interspersed with long distance dispersals. This characterisation holds true throughout the
72 course of the Mesozoic (252 – 66mya) in each of the Triassic (252 – 201 mya), Jurassic (201
73 – 145 mya) and Cretaceous (145 – 66 mya) periods which is demonstrated by the bimodality

74 of the distributions of distances travelled along each branch of the phylogeny (Figure 2a). The
75 terminal branch leading to the flightless Mesozoic bird, Patagopteryx represents the greatest
76 distance associated with an individual branch in the phylogenetic tree. Over 52 million years
77 the ancestral populations of this species moved more than 19,000km which equates to just
78 under half the circumference of the Earth at the equator. On average however, ancestral
79 populations moved a distance (\pm standard deviation) of $2,141 \pm 20$ km before being classed as
80 a new species (average branchwise distance) which is equal to the distance between London
81 and Kiev.

82 Previous work based on inspection of the fossil record alone often implies that
83 dinosaurs were in some way latitudinally restricted in their movement or that areas of
84 endemism are consistent with the idea of floral and faunal distributions occurring in latitudinal
85 belts¹¹⁻¹³ owing to climate¹⁴⁻¹⁶, geographical barriers¹⁷ or competition¹⁸. By considering the
86 complete evolutionary history of each dinosaur species in the phylogeny (i.e. movement from
87 root to each terminal branch via estimated intermediate ancestral locations) rather than the
88 fossils alone, we see no such restriction in the dinosaurs' movement through time as dinosaur
89 species routinely traverse between northern and southern landmasses (Figure 1). Considering
90 a larger geographic and taxonomic scale than that of an individual species' path, we find that
91 the dinosaurs expanded from South America in every possible direction (Figure 2b) to inhabit
92 all available land. However we find that there is some variation through time in the distance
93 travelled in each direction (Figure 2a). In the Triassic the greatest distances covered were
94 towards the north, north east and east which supports the notion that the dinosaurs radiated
95 spatially over Pangea from the south west of the landmass (Figure 2 a and b). All migrations
96 in the Triassic occurred rapidly (Figure 2a, Figure 3 a and b) but those towards the south
97 (given these dispersals only covered short distances) and north east were fastest at an
98 average speed (\pm standard deviation) of 349 ± 1.32 km/my. In the Jurassic, movement towards
99 the north west was favoured, closely followed by dispersal to the north east, west, north and
100 east (Figure 2a) suggesting that during the time after their initial expansion the dinosaurs

101 moved predominantly to cover longitudinal space. This is in contrast to the directions moved
102 in the Cretaceous which again favour latitudinal radiation; species travelled an average of
103 1000km towards the north whilst those moving in all other directions on average traversed
104 less than half this distance. During the Cretaceous all movement was slow (Figure 2 a and
105 Figure 3 a and b), with even the fastest dispersals towards the north occurring 1.5 times slower
106 than the fastest movement in the Triassic. Without the ability to accurately estimate ancestral
107 locations, such nuances of dinosaur biogeography have previously remained a mystery.

108 Our ancestral location reconstructions and branchwise distances travelled allow us to
109 statistically test hypotheses about whether and how distance moved and speed of movement
110 changed over millions of years of dinosaur evolution. In addition, given we know that
111 speciation and spatial distribution are intimately linked¹⁹ we can also use this information to
112 reveal how biogeography interacts with speciation and abiotic factors to provide a better
113 understanding of the dinosaur radiation.

114 To this end, taking into account the uncertainty associated with our reconstructed
115 ancestral locations we ran a series of 1000 Bayesian MCMC phylogenetic generalized least
116 squares regressions with pathwise distance (distances travelled from the root node to each
117 terminal branch) as the dependent variable and path length (time elapsed since the root,
118 measured in millions of years) as the independent variable; enabling us to study the speed of
119 movement through time (see Methods). We allowed the speed to vary over time (including a
120 second order polynomial term for path length) and assessed the impact of other biological
121 variables including speciation rate (node count), diet, gait and taxonomic group (Ornithischia,
122 Theropoda, Sauropodomorpha, paraves and Aves), sampling biases such as formation count
123 and valid count³ and sea level²⁰ as a proxy for land area. Our model reduction process (see
124 Methods) resulted in a model whereby dinosaur movement reduced and slowed over the
125 course of the Mesozoic. We determined parameters to be significant if they were significantly
126 different from zero in >95% of the regressions; %MCMC₁₀₀₀ > 95. All groups of dinosaurs
127 exhibited a universal relationship between distance moved and time (path length %MCMC₁₀₀₀

128 = 100, path length squared %MCMC₁₀₀₀ = 100). We also found no effect of gait or diet on the
129 pathwise distances moved by the dinosaurs and likewise no effect of formation count, sea
130 level or valid count.

131 It has previously been demonstrated³ that speciation rate in dinosaurs declines through
132 time and so to allow for this we also tested the significance of the interaction between path
133 length and speciation rate. As expected there is a strong interactive effect (%MCMC₁₀₀₀ = 100;
134 Figure 3 b and c) which means that the dinosaurs' speed of movement not only decreases
135 over time, but is also further adjusted by speciation, which itself declines with time. As the
136 Mesozoic proceeded, and as more speciation occurred along a lineage, the slower a resultant
137 species moved across the Earth (Figure 3 a-c). The variables in our final regression model
138 explain just under half of the variation in distance moved (mean $R^2 = 0.46$, calculated from the
139 mean R^2 of each of the posteriors for the 1000 regressions). The parameters associated with
140 speciation rate on average contributed approximately 50% of this R^2 value confirming the
141 importance of speciation dynamics in determining faunal distributions.

142 Our results point to an interesting new view of biological radiations. Slowdowns in
143 evolutionary rates through time, be they associated with morphology or speciation, have
144 historically been recognised as representing a so called *adaptive radiation*^{21,22}. The slowdown
145 phenomenon has been widely reported and is often considered pervasive in nature (but see²³)
146 with famous examples ranging from cichlid fishes²⁴, to Anolis lizards²⁵, Darwin's finches²⁶
147 (albeit these examples are geographically restricted) and more recently, dinosaurs³ but yet
148 the causes underpinning this type of radiation pattern remain unclear. Osborn^{27,28} who first
149 coined the term adaptive radiation considered that species emerge in response to adaptive or
150 "mechanical" changes associated with ecological opportunity (the number of open or
151 underused niches within an environment). Subsequently however, emphasis has been placed
152 on the role of physical barriers isolating populations and preventing gene flow as the trigger
153 for speciation; this being considered to result in a non-adaptive radiation²⁹⁻³³. However, it is
154 almost certain that in reality, evolutionary radiations are initiated by and maintained via a

155 complex cocktail of both physical barriers and adaptation to new ecological opportunities.
156 Whilst we may never be able to identify all of the ingredients of this cocktail, an adaptive
157 radiation cannot be truly identified or understood considering speciation or morphological
158 change alone but must be viewed in the light of spatial data. Therefore, our results provide the
159 hitherto missing geographical link, by demonstrating that in dinosaurs at least, rates of
160 movement through time show those characteristic patterns seen in rates of morphological
161 change and speciation. As such, for the first time, we have revealed the geographic signature
162 of an evolutionary radiation - some of which will have certainly been the product of adaptation.

163 Early dinosaurs moved and speciated rapidly with both processes slowing through
164 time. This pattern is consistent with the hypothesis that speciation was first driven by
165 geographical isolation, but as space became limited the dinosaurs moved less and thus the
166 pressure to become specialised and use resources present in the increasingly saturated
167 environment resulted in sympatric speciation. Or perhaps, both geographical and sympatric
168 speciation were co-occurring early in the history of the dinosaurs and as time went on, the
169 balance shifted and sympatric speciation began to dominate. An example of this may have
170 been the case of the paravians, or later avians where, not being able to move into new
171 environments to evade competition with other theropods, they adapted and specialised to
172 occupy aerial space. This ability to overcome the limit on terrestrial space and take advantage
173 of the unoccupied niches may well have laid the foundation for their survival of the end
174 Cretaceous mass extinction that killed non-Avian dinosaurs and their subsequent
175 diversification into one of the most successful vertebrate groups today. A further example is
176 the duck-billed dinosaurs (Hadrosaurs) which were found to evade the late Cretaceous
177 slowdown in speciation rate³ and which we find to move particularly slowly (Figure 3a). The
178 Hadrosaurs' cranial ornamentation has been hypothesised as being a product of sexual
179 selection^{34,35} which is one of the proposed mechanisms for sympatric speciation^{36,37}. This adds
180 credence to our hypothesis that this mode of speciation may have become more common as
181 space became limited.

182 Conclusion

183 Whilst the case of the dinosaurs provides a magnificent example of how we can study
184 millions of years of complex biogeographical dynamics, it also allows us to address important
185 and long standing questions about how organisms evolve and why they exist where they do.
186 Using data regarding movement through time has enabled us to uncover that speciation and
187 therefore dinosaur diversity is propagated by a combination of geographical isolation and *in*
188 *situ* adaptation and divergence; the balance of which is dependent on the availability of
189 physical space. This highlights that sympatric speciation does occur in nature and that this
190 kind of speciation makes a real contribution to the diversity of life on Earth. By uncovering the
191 links between speciation and movement we have revealed that it is possible to detect an
192 evolutionary radiation from data regarding movement in space and time. This means that we
193 can now consider the pivotal spatial mechanisms underpinning famous evolutionary
194 processes such as adaptive radiations without relying solely on patterns in morphological trait
195 data. Using a combination of fossil data, phylogenetic trees and the most realistic
196 biogeographical model to date, we can finally shine light on the evolution of diversity through
197 deep time and understand the processes governing how life is distributed over the planet,
198 even in organisms that went extinct over 66 million years ago.

199

200 Methods

201 1. Biogeographical data and phylogenies

202 We used geographical data downloaded from the PaleoBiology Database* via the Fossilworks
203 portal (<http://fossilworks.org/>) concerning the fossils of the Dinosauromorpha (which includes
204 non-dinosaur dinosauromorphs and the Dinosauria). Specifically, the data regarding species'
205 locations were paleocoordinate data which describe the longitudinal and latitudinal positions
206 of the fossils at the time from which they were deposited (Figure 4).

207 We sourced the paleomap reconstruction coordinates through the Application
208 Programme Interface (API) of the programme Macrostrat (<https://macrostrat.org/>) which uses
209 the GPlates plate reconstruction model³⁸. We sourced a map for each of the 30 Ages in the
210 Mesozoic and plotted them in base R³⁹.

211 In order to account for the fact that species' data are non-independent⁴⁰ we study the
212 spread of the dinosaurs using the two phylogenies constructed by Benson *et al.*,⁸ which are
213 super trees which differ slightly in their topologies. We time calibrate the trees by scaling them
214 using the mid-range value of the first appearance date (FAD) with the branch then extended
215 to the mid-range value of the last appearance data (LAD) for each species. We used the age
216 data from Benson *et al.*⁸ to do this. We chose to use this method on the basis that the mid-
217 range ages are good estimates of the FAD and LAD and work within the given uncertainty that
218 surrounds the dates. This method results in conservative estimates of the branch lengths
219 (measured in millions of years) and thus also of the evolutionary rates. Our analyses are based
220 on the assumption that these phylogenies provide a relatively reliable estimate of dinosaur
221 evolutionary time scales. We used the 'mbf' method of the R package 'paleotree'^{39,41} enforcing
222 a minimum branch length of one million years.

223 Both trees contain 624 species of which we have data for 596 dinosaurs and 10
224 dinosauromorphs (which are included in the ancestral location reconstruction to aid in the
225 estimation of the root location but subsequently removed from all other analyses). All analyses
226 were run using both phylogenies to test the robustness of our method in the face of minor
227 topological uncertainties. Results presented are those from 'Tree 1' only (chosen arbitrarily)
228 owing to the fact that analyses on both trees yielded qualitatively the same results.

229

230 2. Ancestral Location Reconstruction

231 In previous studies of faunal biogeography both actual and reconstructed biogeographical
232 data were treated as discrete areas such as whole continents⁴²⁻⁴⁶ (as recent examples). This

233 confines ancestral areas to the same finite locations as their descendent species at the tips of
 234 the phylogeny and limits the resolution of the information we can glean about a group's
 235 biogeographical history. We therefore build upon more recent work reconstructing locations in
 236 continuous space⁴⁷⁻⁵¹ in three dimensions^{9,52}. Our biogeographical model is implemented in
 237 the computer program *BayesTraits*⁵³.

238 When using longitude and latitude as indicators of location over the entire Earth, the
 239 nature of the non-continuity of longitude's scale means that geographically close locations
 240 appear numerically far apart and thus, ancestral locations are reconstructed erroneously
 241 (Figure 5). To study biogeographical spread we model the Earth as a more realistic sphere
 242 and therefore convert locations from longitude and latitude into coordinates in three
 243 dimensional space (x, y and z) using the following formulae^{54,55}:

244 Conversion to x, y, z

$$245 \quad X = (N + h) \cos \varphi \cos \lambda$$

$$246 \quad Y = (N + h) \cos \varphi \sin \lambda$$

$$247 \quad Z = ((b^2 / a^2) N + h) \sin \varphi$$

248

249 Conversion to longitude and latitude

$$250 \quad \Phi = \arctan ((Z + e'^2 b \sin^3 \theta) / (\rho - e^2 a \cos^3 \theta))$$

$$251 \quad \lambda = \arctan (Y / X)$$

252

253 where **X**, **Y**, **Z** are the three dimensional coordinates of the point in question, **φ** and **λ** represent
 254 the latitude and longitude respectively of the point and **h** is the height of the point above the
 255 surface of the Earth; for simplicity this was kept at zero in our conversions. **a** and **b** are the
 256 lengths of the Earth's semi-major (6,384 km) and semi-minor (6,353 km) axes (radii) which we

257 set as both equal to the mean of 6,371km given that we model the Earth as a perfect sphere.
 258 N is the curvature of the radius of the prime vertical (which describes the radius taken
 259 perpendicular to the point on the surface of the Earth until the polar axis is intersected) and is
 260 calculated by:

$$N = \frac{a^2}{\sqrt{a^2 \cos^2 \varphi + b^2 \sin^2 \varphi}}$$

261
 262
 263 e^2 is the eccentricity squared calculated by $(a^2 + b^2)/a^2$ whilst e'^2 is the second eccentricity
 264 squared and calculated by $(a^2 + b^2)/b^2$. An auxiliary quantity, θ , is calculated by $(Z a / \rho b)$ and
 265 lastly ρ which is equal to $\sqrt{X^2 + Y^2}$.

266 To estimate ancestral locations we take advantage of the wealth of available dinosaur
 267 occurrence data and we sample these multiple tip locations in proportion to their probability
 268 (Figure 6). This avoids using centroids which are non-representative averages⁵⁶ of multiple
 269 geographical locations.

270 We estimate the ancestral positions, by first proposing a location that is an average of
 271 the longitude and latitude of its descendants. For each iteration of ancestral locations we move
 272 a certain distance (set by estimating the distance within which approximately 30% of
 273 suggested locations will be accepted) and random bearing away from this starting point.
 274 Subsequently proposed locations are made in three dimensional space which are then
 275 converted into longitude and latitude, to confirm that the location is on the surface of the Earth,
 276 and then converted back to an XYZ coordinate. This process continues as long as the MCMC
 277 chain proceeds with both tip and ancestral locations accepted in proportion to their probability.

278 Along with the tip and ancestral locations we simultaneously estimate the rates of
 279 evolution acting across the single phylogeny. We use the variable rates model of Venditti *et*
 280 *al.*¹⁰ which detects shifts away from the background rate of evolution (or expectation under a
 281 Brownian motion model of evolution) in whole clades of the phylogeny or on individual

282 branches. Where previously ancestral states were implied in the model we now estimate them
283 explicitly along with the rates and both are included in the calculation of the likelihood which
284 follows the method of Elliot and Mooers⁵⁷:

$$285 \quad L(X, \sigma; T) = \prod_b \phi(b_2 - b_1; t_n \sigma^2)$$

286 The likelihood is calculated given some data (X) for a continuously varying trait with a variance
287 (σ^2) for a given tree (T). The probability of an ancestral state is calculated using the difference
288 between the ancestral and descendent trait values at either end of a branch ($b_2 - b_1$) and the
289 variance multiplied by that branch's length ($t_n \sigma^2$) where t_n denotes the time (branch length)
290 of a given branch 'n'. This probability is derived for every branch in the tree and then multiplied
291 together and log transformed to give the final log likelihood for a single iteration of the MCMC
292 chain.

293 Lending credence to the realism of our model, 99.2% of our mean reconstructions are
294 located within the bounds of the landmasses specific to the time period at which they occurred
295 without having constrained the model with *a priori* information about the location of coastlines.

296

297 3. Converged chains

298 We ran five replicate MCMC chains (discarding at least the first 450 million iterations of each
299 as burnin). We sampled the chain every 50,000 iterations once all chains had reached
300 convergence (as judged by visualizing the variation in the traces of each ancestral state and
301 the likelihood). We concatenated the converged portions of these five chains and used a
302 random 1000 of these samples in all downstream analyses.

303

304

305

306 4. Branchwise and Pathwise Distances

307 Having included the ten dinosauromorphs in the phylogeny to aid in estimating an accurate
308 location for the root ancestor of the dinosaurs, we subsequently removed them from all further
309 analyses, being concerned with only the movement of the species within Dinosauria. In order
310 to study the distances travelled through time by the dinosaurs we calculated a pathwise
311 distance for every dinosaur in the phylogeny (n=595). We did this by taking one of the 1000
312 samples of ancestral and tip locations at a time and calculating the distance between every
313 ancestor and descendent in the tree. These branchwise distances were calculated using the
314 'distCosine' function of the 'geosphere' package in R⁵⁸. This method calculates the great circle
315 distance (the shortest distance) between two points on a sphere measured in kilometres using
316 the Spherical Law of Cosines which works for calculating these distances at both large and
317 small scales. When all branchwise distances have been calculated the result is a distribution
318 of 1000 distances for every branch in the tree.

319 Branchwise distances were then combined to make root-to-tip pathwise distances by
320 summing all the distances along a tip's path. Again, this is done for every set of distances in
321 the posterior which means we have 1000 pathwise distances for every tip species in the tree.
322 This means that our final measures of distance moved by the dinosaurs incorporates both the
323 variation in fossil locations and the uncertainty in our ancestral location estimates. All pathwise
324 distance measurements were \log_{10} transformed before use in further analyses.

325 We attribute the branchwise distances and thus also then the total distance associated
326 with each species to biological or species' movement. However given the major continental
327 conformation changes that occurred during the Mesozoic, it is possible that some of the
328 distance moved is attributable to continental movement, which we do not account for in our
329 model. During each major time period of the Mesozoic we detect movement in every direction
330 which would not be the case if the species were solely being carried by continental drift. This
331 is particularly the case in times where we find directional movement as it is unlikely that all
332 continents at this time were also exclusively moving in these directions, therefore meaning

333 that it must have been biological movement. We believe that overall, given the global nature
334 of these data that the effects of continental movement on the pattern of dinosaur spread we
335 detect would be minimal. Given this pattern we also feel that the biological and ecological
336 forces acting to determine where species could exist and how far they could move would
337 outweigh the influence of continental movement (akin to the results of Dunhill *et al.*⁵⁹).

338

339 5. Phylogenetic Regressions and Model Reduction

340 Pathwise distances allow us to quantify the convoluted paths that the ancestral dinosaurs
341 traversed which eventually resulted in the distributions of the dinosaur species that we have
342 evidence of today. To explore whether there is a relationship between distances moved and
343 time and whether this differs amongst the major groups of dinosaurs we ran phylogenetic
344 Generalised Least Squares regressions in a Bayesian MCMC framework⁵³. We modelled \log_{10}
345 pathwise distance as the response variable with path length (time elapsed since the root) as
346 the predictor variable. In addition we included several bias metrics as covariates in these
347 regressions in order to account for the largely incomplete fossil record⁶⁰. We included valid
348 count which quantifies the known under-representation of a subclade in a given phylogeny
349 taken from the SI of Sakamoto *et al.*³. Formation count (the number of formations present at
350 a particular geological time) is known to be associated with sampling bias^{61,62} and thus we
351 included stage-specific formation count which describes the number of formations in each
352 geological stage for every species in the tree, again using the data and protocol of Sakamoto
353 *et al.*³. To study the relationship between distance moved and speciation we calculated the
354 number of ancestral nodes in the phylogeny that preceded every species at the tips of the
355 tree. These values were \log_{10} transformed and log Node Count used as a measure of
356 speciation rate. Akin to Sakamoto *et al.*³ we used the sea level data of Haq *et al.*²⁰ as a proxy
357 for land area to see the impact of this on dinosaur movement. We also included data on diet
358 (carnivore or not; see Supplementary Data 1) and gait (quadruped, semi-biped or biped; see
359 Supplementary Data 1) to see whether these ecological factors had differential impacts on the

360 dinosaurs' movements. Our sample size was reduced to 595 species due to a lack of gait data
361 for all of the species with geographical data.

362 We began with two regression models, one separating dinosaurs into Ornithischians,
363 Sauropodomorphs, non-paravian Theropods and paraves (henceforth to be referred to as
364 the paravian model) and the other with dinosaurs split into Ornithischians, Sauropodomorphs,
365 non-Avian Theropods and Aves (henceforth the avian model). These groupings are well
366 supported biologically and due to prior knowledge regarding differences in the groups' overall
367 biology it seemed logical to test whether these differences impacted their movement through
368 time. The initial models estimated separate intercepts, slopes and quadratic terms for each of
369 the four groups whilst also incorporating the above mentioned covariates and group-gait
370 interactions. We reduced these models using a strict protocol of removing the single most non-
371 significant parameter and then rerunning the resulting models until we reached a single model
372 where all of the parameters were significant. Parameter significance was judged by calculating
373 a pMCMC value for each posterior of regression coefficients where $< 5\%$ or $> 95\%$ of the
374 samples crossing zero indicates that the posterior of parameter estimates is significantly
375 different from zero. Once this pMCMC value had been calculated for all model parameters in
376 all of the 1000 regression posteriors, the percentage of the 1000 regressions where a
377 parameter was significant (pMCMC < 0.05 (5%) or > 0.95 (95%)) was calculated and is
378 referred to as the %MCMC₁₀₀₀ value. If the %MCMC₁₀₀₀ value for a given parameter was > 95
379 (the parameter was significantly different from zero in $>95\%$ of the regressions) the parameter
380 was considered as significant, otherwise it was considered for removal from the model.

381 The paravian and avian models reduced to the same model owing to the lack of
382 significance of individual groups' quadratics, slopes and intercepts. This resulted in a model
383 which estimated one intercept, slope and quadratic for all dinosaurs in one group, taking into
384 account speciation (model: Distance \sim PL + PL² + logNodeCount) and where all parameters
385 were significant in all 1000 regressions. On the basis that Sakamoto *et al.*³ found that
386 speciation slowed through time we tested our model with an additional quadratic term,

387 logNodeCount² which we also found to be significant. Lastly, we modified our model to test
 388 whether there was an interaction between speciation and time given that there is a statistical
 389 complication associated with estimating two quadratic terms without an interaction and
 390 likewise with estimating an interaction without two quadratics⁶³. We found that this product
 391 term significantly improved the model (Distance ~ PL + PL² + logNodeCount + logNodeCount²
 392 + PL*logNodeCount; see Table 1). These parameters explained almost half of the variation in
 393 distance moved (mean R² of the 1000 regressions = 0.46).

394

Table 1 – the percentage of the 1000 regressions where each parameter in the final model is significantly different from zero (%MCMC₁₀₀₀; significant is > 95)

Alpha	PL	PL ²	logNodeCount	logNodeCount ²	PL*logNodeCount
100	100	100	100	95.4	99.3

395

396

397 6. Direction analyses

398 For every branch in the tree, given the ancestral and descendent locations we calculated the
 399 bearing between the two points. We then categorised this bearing value into eight direction
 400 categories (North, North east, East, South east, South, South west, West, North west) with
 401 each describing a 45° portion of a circle. We did this for each branch (n=1084) for each set of
 402 ancestral locations (n=1000). To test whether branchwise speed of movement and branchwise
 403 distances were different in each direction in each of the geological time periods of the
 404 Mesozoic (Triassic, Jurassic and Cretaceous) we ran standard least squares regressions in
 405 REML in JMP, Version 7⁶⁴. We modelled branchwise distance (and speed in a second
 406 analysis) as the response variable with branchwise direction category as the explanatory
 407 variable with dataset (the 1000 sets of branchwise data were concatenated but marked by a

408 dataset number of 1 to 1000) accounted for as a random effect. This allowed us to partition
409 out the variance in branchwise distance or speed arising between the 1000 samples of
410 ancestral states. We carried out post hoc Tukey Honestly Significant Difference tests on the
411 three regressions (one for each time period of the Mesozoic) for the models with distance and
412 speed in the eight directions. The results of these indicated the magnitude of the mean
413 distance or mean speed travelled in each direction and which of these were significantly
414 different to each other.

415

416 **Acknowledgements**

417 We thank Mike Benton and Manabu Sakamoto for help with classifying dinosaur diet and gait
418 and John Czaplewski for help with obtaining the paleomaps. We are also grateful to Joanna
419 Baker, Henry Ferguson-Gow, Jorge Avaria-Llautureo, Simon Branford, Louise Johnson, Igor
420 Siveroni and Mark Pagel for helpful discussion. This work is supported by The Leverhulme
421 Trust (RPG-2013-185 and RPG-2017-071) and the BBSRC (BB/L018594/1).

422

423 **Contributions**

424 All authors contributed to all aspects of this work.

425

426 **Competing financial interests**

427 The authors declare no competing financial interests.

428

429 **Data availability**

430 All data generated or analysed during this study are included in the Supplementary Data file.

431

432 **Code availability**

433 All analyses were run using the computer program BayesTraits version 3 which is freely
434 available from www.evolution.rdg.ac.uk/BayesTraitsV3.0.1/BayesTraitsV3.0.1.html.

435

436

437

438

439

440

441

442

443

444

445

446

447

448

449

450

451

452

453 **References**

- 454 1 Brusatte, S. L., Benton, M. J., Ruta, M. & Lloyd, G. T. The first 50Myr of dinosaur
455 evolution: macroevolutionary pattern and morphological disparity. *Biology letters* **4**,
456 733-736, doi:10.1098/rsbl.2008.0441 (2008).
- 457 2 Brusatte, S. L., Benton, M. J., Ruta, M. & Lloyd, G. T. Superiority, competition and
458 opportunism in the evolutionary radiation of dinosaurs. *Science* **321**, 1485-1488
459 (2008).
- 460 3 Sakamoto, M., Benton, M. J. & Venditti, C. Dinosaurs in decline tens of millions of
461 years before their extinction. *Proc. Natl. Acad. Sci. U.S.A.* **113**, 5036-5040 (2016).
- 462 4 Sereno, P. C. The origin and evolution of dinosaurs. *Annual Review of Earth and*
463 *Planetary Sciences* **25**, 435-489, doi:10.1146/annurev.earth.25.1.435 (1997).
- 464 5 Martinez, R. N. *et al.* A basal dinosaur from the dawn of the dinosaur era in
465 Southwestern Pangaea. *Science* **331**, 206-210, doi:10.1126/science.1198467 (2011).
- 466 6 Langer, M. C., Ezcurra, M. D., Bittencourt, J. S. & Novas, F. E. The origin and early
467 evolution of dinosaurs. *Biological Reviews* **85**, 55-110, doi:10.1111/j.1469-
468 185X.2009.00094.x (2010).
- 469 7 Brusatte, S. L. *et al.* The origin and early radiation of dinosaurs. *Earth-Science*
470 *Reviews* **101**, 68-100, doi:10.1016/j.earscirev.2010.04.001 (2010).
- 471 8 Benson, R. B. J. *et al.* Rates of dinosaur body mass evolution indicate 170 million
472 years of sustained ecological innovation on the avian stem lineage. *PLoS Biology* **12**,
473 e1001853, doi:10.1371/journal.pbio.1001853 (2014).
- 474 9 Bouckaert, R. Phylogeography by diffusion on a sphere: whole world
475 phylogeography. *PeerJ* **4**, e2406 (2016).
- 476 10 Venditti, C., Meade, A. & Pagel, M. Multiple routes to mammalian diversity. *Nature*
477 **479**, 393-396, doi:10.1038/nature10516 (2011).

- 478 11 McAllister Rees, P., Noto, C. R., Parrish, J. M. & Parrish, J. T. Late Jurassic climates,
479 vegetation, and dinosaur distributions. *The Journal of Geology* **112**, 643-653,
480 doi:10.1086/424577 (2004).
- 481 12 Ezcurra, M. D. Biogeography of Triassic tetrapods: evidence for provincialism and
482 driven sympatric cladogenesis in the early evolution of modern tetrapod lineages.
483 *Proceedings of the Royal Society Biological Sciences Series B* **277**, 2547-2552,
484 doi:10.1098/rspb.2010.0508 (2010).
- 485 13 Mannion, P. D. *et al.* A temperate palaeodiversity peak in Mesozoic dinosaurs and
486 evidence for Late Cretaceous geographical partitioning. *Global Ecology and*
487 *Biogeography* **21**, 898-908, doi:10.1111/j.1466-8238.2011.00735.x (2012).
- 488 14 Noto, C. R. & Grossman, A. Broad-scale patterns of late jurassic dinosaur
489 paleoecology. *PLoS One* **5**, e12553, doi:10.1371/journal.pone.0012553 (2010).
- 490 15 Brusatte, S. L. *Dinosaur paleobiology*. Vol. 2 (Wiley, 2012).
- 491 16 Herman, A. B., Spicer, R. A. & Spicer, T. E. V. Environmental constraints on
492 terrestrial vertebrate behaviour and reproduction in the high Arctic of the Late
493 Cretaceous. *Palaeogeography, Palaeoclimatology, Palaeoecology* **441**, 317-338,
494 doi:<http://dx.doi.org/10.1016/j.palaeo.2015.09.041> (2016).
- 495 17 Longrich, N. R. A ceratopsian dinosaur from the Late Cretaceous of eastern North
496 America, and implications for dinosaur biogeography. *Cretaceous Research* **57**, 199-
497 207, doi:10.1016/j.cretres.2015.08.004 (2016).
- 498 18 Longrich, N. R. The horned dinosaurs Pentaceratops and Kosmocerotops from the
499 upper Campanian of Alberta and implications for dinosaur biogeography. *Cretaceous*
500 *Research* **51**, 292-308, doi:10.1016/j.cretres.2014.06.011 (2014).
- 501 19 Wiens, J. J. The causes of species richness patterns across space, time, and clades
502 and the role of “ecological limits”. *The Quarterly Review of Biology* **86**, 75-96,
503 doi:10.1086/659883 (2011).
- 504 20 Haq, B. U., Hardenbol, J. & Vail, P. R. Chronology of fluctuating sea levels since the
505 Triassic. *Science* **235**, 1156-1167, doi:10.1126/science.235.4793.1156 (1987).

- 506 21 Simpson, G. G. *Tempo and Mode in Evolution*. (Columbia University Press, 1944).
- 507 22 Schluter, D. *The Ecology of Adaptive Radiation*. (Oxford University Press Inc., New
508 York, 2000).
- 509 23 Venditti, C., Meade, A. & Pagel, M. Phylogenies reveal new interpretation of
510 speciation and the Red Queen. *Nature* **463**, 349-352, doi:10.1038/nature08630
511 (2010).
- 512 24 Seehausen, O. African cichlid fish: a model system in adaptive radiation research.
513 *Proceedings of the Royal Society Biological Sciences Series B* **273**, 1987-1998,
514 doi:10.1098/rspb.2006.3539 (2006).
- 515 25 Mahler, D. L., Revell, L. J., Glor, R. E. & Losos, J. B. Ecological opportunity and the
516 rate of morphological evolution in the diversification of greater Antillean anoles.
517 *Evolution; international journal of organic evolution* **64**, 2731-2745,
518 doi:10.1111/j.1558-5646.2010.01026.x (2010).
- 519 26 Grant, P. R. Speciation and the adaptive radiation of Darwin's finches: The complex
520 diversity of Darwin's finches may provide a key to the mystery of how intraspecific
521 variation is transformed into interspecific variation. *American Scientist* **69**, 653-663
522 (1981).
- 523 27 Osborn, H. F. The geological and faunal relations of Europe and America during the
524 Tertiary period and the theory of the successive invasions of an African fauna.
525 *Science* **11**, 561-574 (1900).
- 526 28 Foth, C., Brusatte, S. L. & Butler, R. J. Do different disparity proxies converge on a
527 common signal? Insights from the cranial morphometrics and evolutionary history of
528 Pterosauria (Diapsida: Archosauria). *Journal of evolutionary biology* **25**, 904-915,
529 doi:10.1111/j.1420-9101.2012.02479.x (2012).
- 530 29 Erwin, D. H. A preliminary classification of evolutionary radiations. *Historical Biology*
531 **6**, 133-147, doi:10.1080/10292389209380423 (1992).

- 532 30 Losos, J. B. & Miles, D. B. Testing the hypothesis that a clade has adaptively
533 radiated: Iguanid lizard clades as a case study. *The American Naturalist* **160**, 147-
534 157, doi:10.1086/341557 (2002).
- 535 31 Abe, F. R. & Lieberman, B. S. The nature of evolutionary radiations: a case study
536 involving Devonian Trilobites. *Evolutionary Biology* **36**, 225-234, doi:10.1007/s11692-
537 009-9060-0 (2009).
- 538 32 Rundell, R. J. & Price, T. D. Adaptive radiation, nonadaptive radiation, ecological
539 speciation and nonecological speciation. *Trends in ecology & evolution* **24**, 394-399,
540 doi:<http://dx.doi.org/10.1016/j.tree.2009.02.007> (2009).
- 541 33 Simões, M. *et al.* The evolving theory of evolutionary radiations. *Trends in ecology &*
542 *evolution* **31**, 27-34, doi:<http://dx.doi.org/10.1016/j.tree.2015.10.007> (2016).
- 543 34 Hone, D. W. E., Naish, D. & Cuthill, I. C. Does mutual sexual selection explain the
544 evolution of head crests in pterosaurs and dinosaurs? *Lethaia* **45**, 139-156,
545 doi:10.1111/j.1502-3931.2011.00300.x (2012).
- 546 35 Padian, K. & Horner, J. R. The evolution of 'bizarre structures' in dinosaurs:
547 biomechanics, sexual selection, social selection or species recognition? *Journal of*
548 *Zoology* **283**, 3-17, doi:10.1111/j.1469-7998.2010.00719.x (2011).
- 549 36 Higashi, M., Takimoto, G. & Yamamura, N. Sympatric speciation by sexual selection.
550 *Nature* **402**, 523-526, doi:<http://dx.doi.org/10.1038/990087> (1999).
- 551 37 Servedio, M. R. & Boughman, J. W. The role of sexual selection in local adaptation
552 and speciation. *Annual Review of Ecology, Evolution, and Systematics* **48**,
553 doi:10.1146/annurev-ecolsys-110316-022905 (2017).
- 554 38 EarthByte Project. *GPlates 1.5*, <<http://www.gplates.org/>> (2015).
- 555 39 R Core Team. R: A language and environment for statistical computing (R
556 Foundation for Statistical Computing, 2016).
- 557 40 Pagel, M. Inferring evolutionary processes from phylogenies. *Zoologica Scripta* **26**,
558 331-348, doi:10.1111/j.1463-6409.1997.tb00423.x (1997).

- 559 41 Bapst, D. W. paleotree: an R package for paleontological and phylogenetic analyses
560 of evolution. *Methods in Ecology and Evolution* **3**, 803-807, doi:10.1111/j.2041-
561 210X.2012.00223.x (2012).
- 562 42 Lawing, A. M. & Matzke, N. J. Conservation paleobiology needs phylogenetic
563 methods. *Ecography* **37**, 1109-1122, doi:10.1111/ecog.00783 (2014).
- 564 43 Walimbe, A. M., Lotankar, M., Cecilia, D. & Cherian, S. S. Global phylogeography of
565 Dengue type 1 and 2 viruses reveals the role of India. *Infection, Genetics and*
566 *Evolution* **22**, 30-39, doi:10.1016/j.meegid.2014.01.001 (2014).
- 567 44 Kaliszewska, Z. A. *et al.* When caterpillars attack: biogeography and life history
568 evolution of the Miletinae (Lepidoptera: Lycaenidae). *Evolution; international journal*
569 *of organic evolution* **69**, 571-588, doi:10.1111/evo.12599 (2015).
- 570 45 Wang, N., Kimball, R. T., Braun, E. L., Liang, B. & Zhang, Z. Ancestral range
571 reconstruction of Galliformes: the effects of topology and taxon sampling. *Journal of*
572 *Biogeography* **44**, 122-135, doi:10.1111/jbi.12782 (2017).
- 573 46 Fernando, S. W., Peterson, A. T. & Li, S.-H. Reconstructing the geographic origin of
574 the New World jays. *Neotropical Biodiversity* **3**, 80-92,
575 doi:10.1080/23766808.2017.1296751 (2017).
- 576 47 Lemmon, A. R. & Lemmon, E. M. A likelihood framework for estimating
577 phylogeographic history on a continuous landscape. *Systematic biology* **57**, 544-561,
578 doi:10.1080/10635150802304761 (2008).
- 579 48 Lemey, P., Rambaut, A., Welch, J. J. & Suchard, M. A. Phylogeography takes a
580 relaxed random walk in continuous space and time. *Molecular Biology and Evolution*
581 **27**, 1877-1885, doi:10.1093/molbev/msq067 (2010).
- 582 49 Walker, R. S. & Ribeiro, L. A. Bayesian phylogeography of the Arawak expansion in
583 lowland South America. *Proceedings of the Royal Society Biological Sciences Series*
584 *B* **278**, 2562-2567, doi:10.1098/rspb.2010.2579 (2011).
- 585 50 Bouckaert, R. *et al.* Mapping the origins and expansion of the Indo-European
586 language family. *Science* **337**, 957-960, doi:10.1126/science.1219669 (2012).

587 51 Grollemund, R. *et al.* Bantu expansion shows that habitat alters the route and pace of
588 human dispersals. *Proceedings of the National Academy of Sciences USA* **112**,
589 13296-13301, doi:10.1073/pnas.1503793112 (2015).

590 52 Bouckaert, R. Phylogeography by diffusion on a sphere. *bioRxiv*, 016311,
591 doi:10.1101/016311 (2015).

592 53 Pagel, M., Meade, A. & Barker, D. Bayesian estimation of ancestral character states
593 on phylogenies. *Systematic biology* **53**, 673-684, doi:10.1080/10635150490522232
594 (2004).

595 54 Hofmann-Wellenhof, B. L., Herbert; Collins, James. *Global Positioning System:
596 Theory and Practice*. (Springer Vienna, 1992).

597 55 Jones, A. Where in the World are We? Version 1.7. (Department for Environment,
598 Heritage and Aboriginal Affairs in cooperation with the South Australian Spatial
599 Information Committee, Government of South Australia, Adelaide South Australia,
600 1999).

601 56 Quintero, I., Keil, P., Jetz, W. & Crawford, F. W. Historical biogeography using
602 species geographical ranges. *Systematic biology* **64**, 1059-1073,
603 doi:10.1093/sysbio/syv057 (2015).

604 57 Elliot, M. G. & Mooers, A. O. Inferring ancestral states without assuming neutrality or
605 gradualism using a stable model of continuous character evolution. *BMC Evol Biol*
606 **14**, 226, doi:10.1186/s12862-014-0226-8 (2014).

607 58 Hijmans, R. *geosphere: Spherical Trigonometry*. R package version 1.3-11.
608 <http://CRAN.R-project.org/package=geosphere>. (2014).

609 59 Dunhill, A. M., Bestwick, J., Narey, H. & Sciberras, J. Dinosaur biogeographical
610 structure and Mesozoic continental fragmentation: a network-based approach.
611 *Journal of Biogeography* **43**, 1691-1704, doi:10.1111/jbi.12766 (2016).

612 60 Alroy, J. Geographical, environmental and intrinsic biotic controls on Phanerozoic
613 marine diversification. *Palaeontology* **53**, 1211-1235, doi:10.1111/j.1475-
614 4983.2010.01011.x (2010).

615 61 Barrett, P. M., McGowan, A. J. & Page, V. Dinosaur diversity and the rock record.
616 *Proc. R. Soc. London Ser. B* **276**, 2667-2674, doi:10.1098/rspb.2009.0352 (2009).

617 62 Upchurch, P., Mannion, P. D., Benson, R. B. J., Butler, R. J. & Carrano, M. T.
618 Geological and anthropogenic controls on the sampling of the terrestrial fossil record:
619 a case study from the Dinosauria. *Geological Society, London, Special Publications*
620 **358**, 209-240, doi:10.1144/sp358.14 (2011).

621 63 Ganzach, Y. Misleading interaction and curvilinear terms. *Psychological Methods* **2**,
622 235 (1997).

623 64 JMP v. 7 (SAS Institute Inc., Cary, NC, 1989-2007).

624 * Paleobiology-Database. (2014). Data downloaded on 8th October 2014, using the
625 group name 'Dinosauria' and the following parameters: latitude/ longitude in decimal,
626 paleolatitude/ paleolongitude in decimal, period, stage, maximum age (Ma), minimum
627 age (Ma), midpoint age (Ma)

628

629

630

631

632

633

634

635

636

637

638

639 **Figure Legends**

640 **Figure 1** - Six reconstructed paths from the dinosaurian root node (black circle) to the
641 fossilised species (black square). The coloured circles represent the centroids of the
642 reconstructed ancestral locations (these are used for visualisation purposes only and posterior
643 distributions of estimated ancestral locations are used in all analyses). Paths are plotted onto
644 geological Age level paleomaps from the time at which the fossil species is dated to (grey)
645 with all preceding Age level paleomap layers plotted in white (see Methods). Paths of **a** -
646 *Rhoetosaurus brownei* (Silhouette of *Spinophorosaurus nigerensis* - credit given to Remes K,
647 Ortega F, Fierro I, Joger U, Kosma R et al.*). **b** - *Archaeopteryx lithographica*. **c** - *Stegosaurus*
648 *stenops* (Credit given to Scott Hartman*). **d** - *Andesaurus delgadoi* (Silhouette of *Wintonotitan*
649 *wattsi* - credit given to T. Tischler*). **e** - *Dromaeosaurus albertensis* (Silhouette of
650 *Dromaeosauroides bornholmensis*). **f** - *Tyrannosaurus rex* (Credit given to Scott Hartman*).

651 All silhouettes downloaded from www.phylopic.org. *This image has permission for reuse
652 under the Creative Commons Attribution-ShareAlike 3.0 Unported license
653 <https://creativecommons.org/licenses/by-sa/3.0/>

654

655

656

657

658

659

660

661

662 **Figure 2 a** - shows the distributions of log transformed branchwise distances (upper) and
663 speeds (lower) for each of the three periods of the Mesozoic era (Triassic in green, Jurassic
664 in red and Cretaceous in purple). Next to each distribution is a 'globe' with arrows, the length
665 and shade of colour of which show the magnitude of distance or speed travelled in the given
666 direction. Arrows in different shades indicate that the mean distance or speed travelled in that
667 direction is significantly different from those travelled in the other directions. Conversely, where
668 arrows are the same colour this indicates that the mean distances or speeds moved in those
669 directions are not significantly different to one another. **b** - The areas covered by the dinosaurs,
670 including both fossilised species' and reconstructed ancestral locations in the Triassic (green
671 area), Jurassic (red area) and Cretaceous (purple area). The areas are plotted onto a map
672 which spans from the beginning of the Triassic to the end of the Cretaceous (white) with the
673 final map layer in grey and outlined in black (see Methods). The root node, or ancestor of all
674 the dinosaurs, is plotted as a black circle.

675

676

677

678

679

680

681

682

683

684

685 **Figure 3 a** - The dinosaur phylogenetic tree with branch lengths measured in millions of years
686 and with each branch coloured to reflect predicted speed of movement calculated from the
687 mean branchwise distance, branch length and the number of preceding speciation events.
688 Silhouettes as in Figure 1. **b** - Interaction plot of predicted distance moved over time at five
689 different rates of speciation (values of log node count). Each regression line plotted is using
690 the mean coefficients from a single MCMC regression. Line in bold represents the prediction
691 made from the mean coefficients of all 1000 regressions. **c** - Interaction plot of the effect of
692 speciation (log node count) on predicted distance at five different times during the Mesozoic
693 (252 – 66 mya). Each regression line plotted is using the mean coefficients from a single
694 MCMC regression. Line in bold represents the prediction made from the mean coefficients of
695 all 1000 regressions.

696

697

698

699

700

701

702

703

704

705

706

707

708 **Figure 4** - The importance of using coordinates that are in both the right geographic and
709 temporal context. **a** - shows a modern map with a paleocoordinate (which occurs in the sea)
710 plotted with its modern counterpart (which correctly, occurs on land). **b** - shows the same
711 coordinates as in **a** but plotted onto a paleomap representing the arrangement of the
712 landmasses during the time period that the paleocoordinate comes from. Now in the correct
713 temporal setting the green circle occurs on land as expected. This also demonstrates the
714 importance of using paleocoordinates to understand past locations accurately; these points
715 are 2949km apart from each other.

716

717

718

719

720

721

722

723

724

725

726

727

728

729

730 **Figure 5 a** - A simple representation of a phylogenetic tree which shows how species A and
731 B are related. The reconstruction of the location of their common ancestor (green square)
732 demonstrates the problem with using longitude (and latitude) to describe locations on a
733 sphere. **b** - Shows the positions of species A and B on a 2D map of the Earth. When
734 considered in a flat context, the two locations appear far apart (distance represented by the
735 red line on the equator). The average of their longitudes is 0° which is where their ancestor's
736 position would erroneously be reconstructed (red diamond). **c** - Illustrates that the two species'
737 locations when considered on a 3D globe (represented by the grey circle as the Earth viewed
738 from above) are very close. This is shown by the green line linking the species with the green
739 square marking where the ancestor would be reconstructed. This green line represents the
740 same green lines as in diagram **b** which are severed as an artefact of projecting the 3D globe
741 onto a flat map projection.

742

743

744

745

746

747

748

749

750

751

752

753

754 **Figure 6** - demonstrates the importance of including all of the available fossil occurrences as
755 data at the tips of the phylogeny used to estimate ancestral locations (green squares). The
756 red ring indicates the position of the centroid calculated given the fossil locations of the species
757 *Dromaeosaurus albertensis* (black crosses). This location is likely to have been occupied by
758 the species but given that no fossils have been found there we work on the basis of using
759 precise locations of fossils that indicate definite presence at a location. Thus, we sample the
760 distribution of locations given for each tip in the phylogeny according to their probability. We
761 therefore incorporate realistic variation in the location of each species when estimating the
762 ancestral locations.

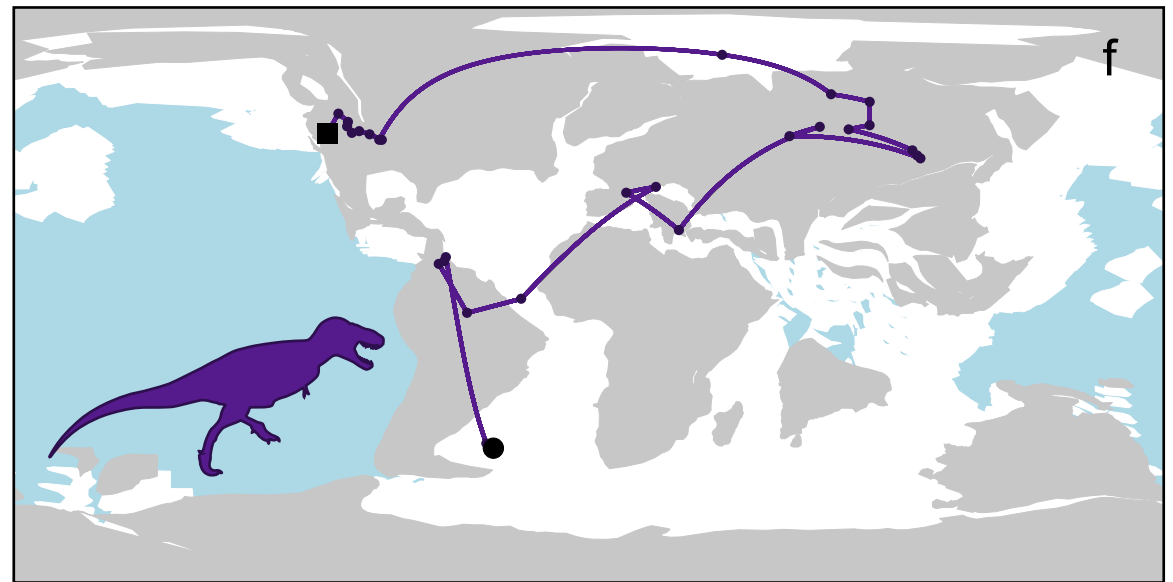
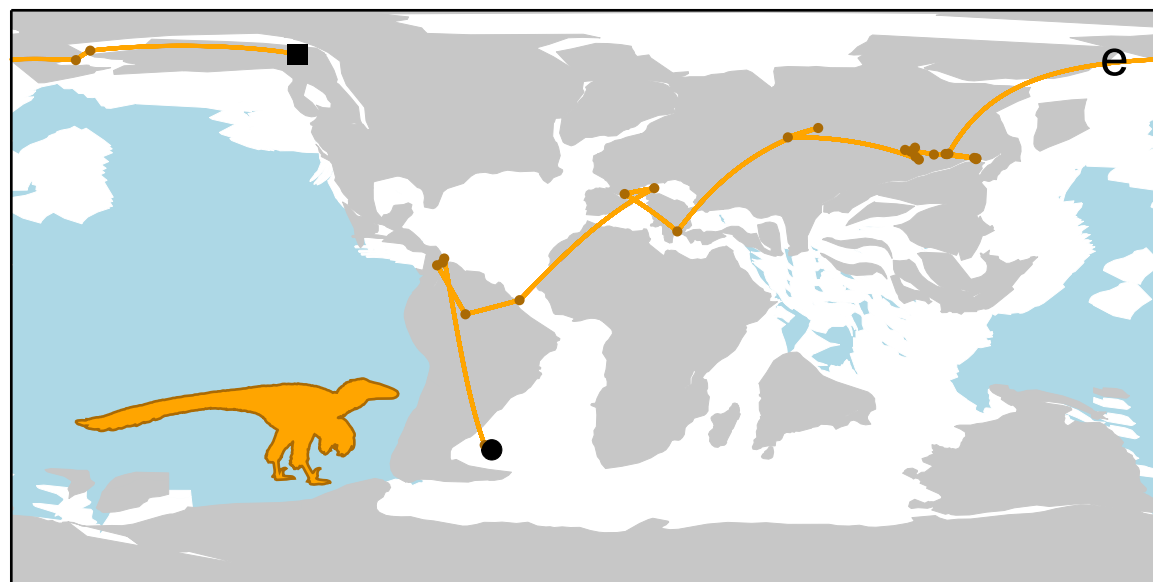
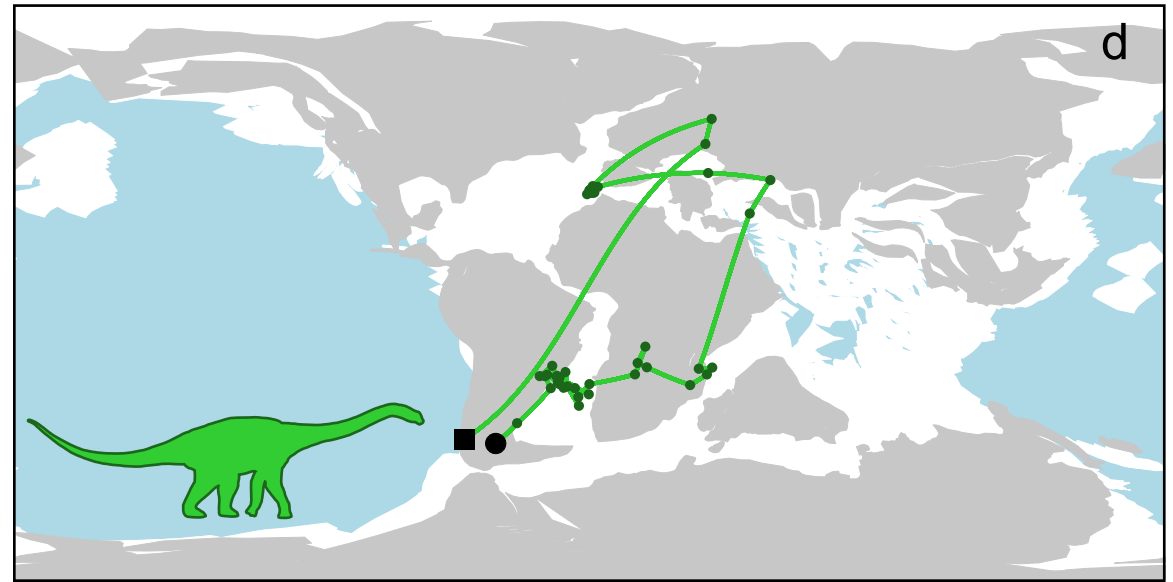
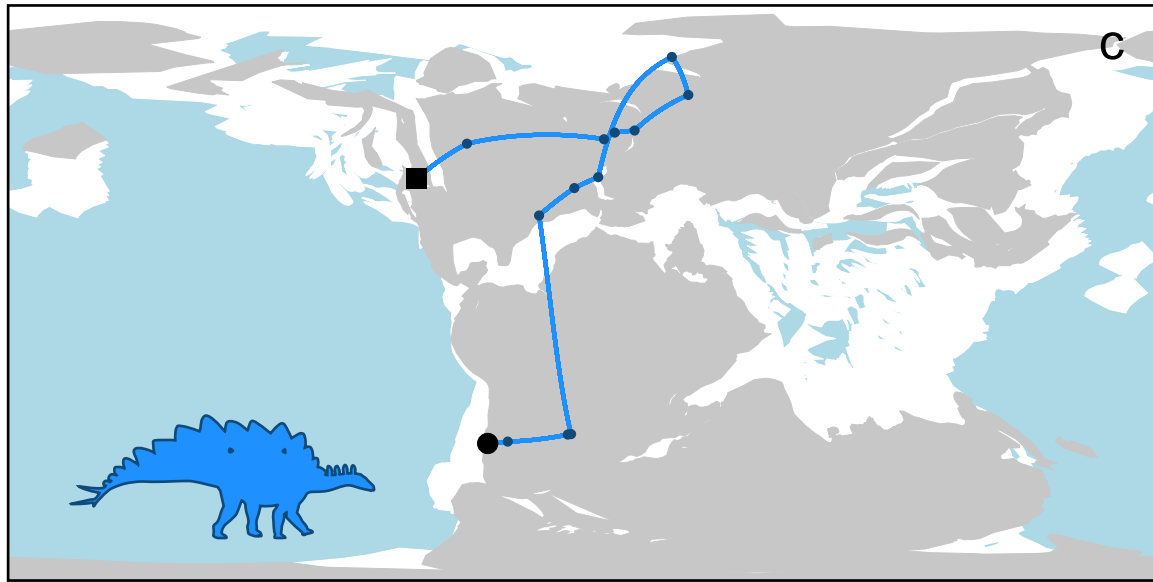
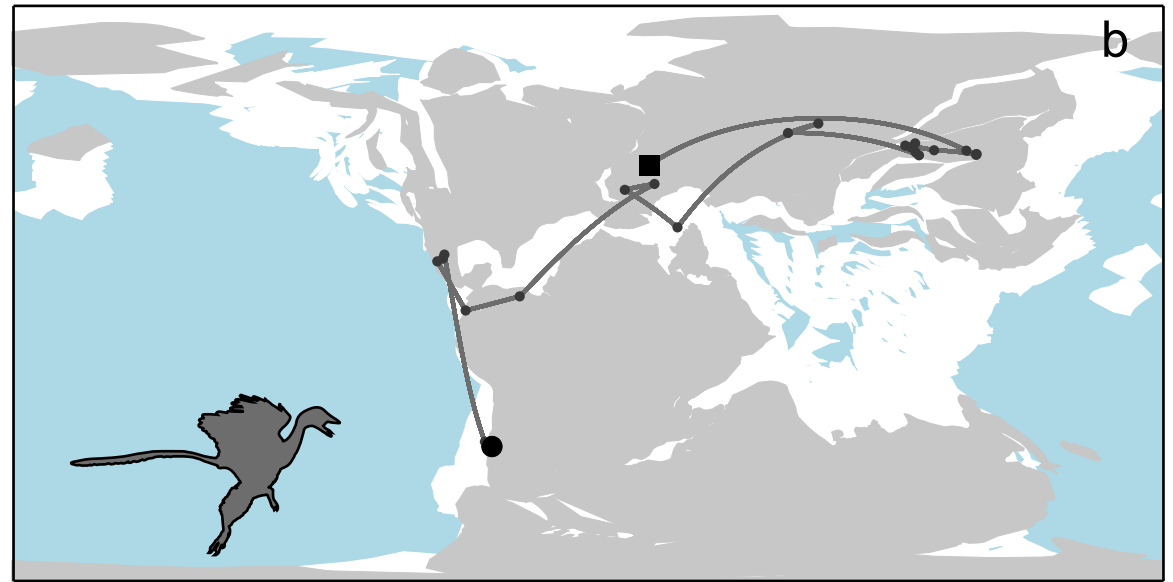
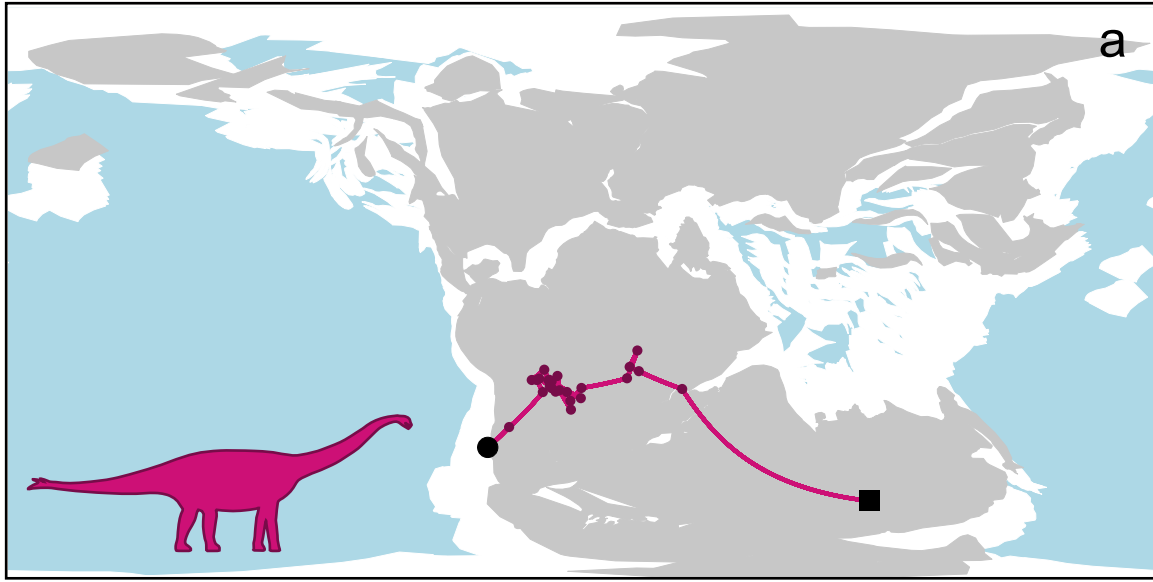

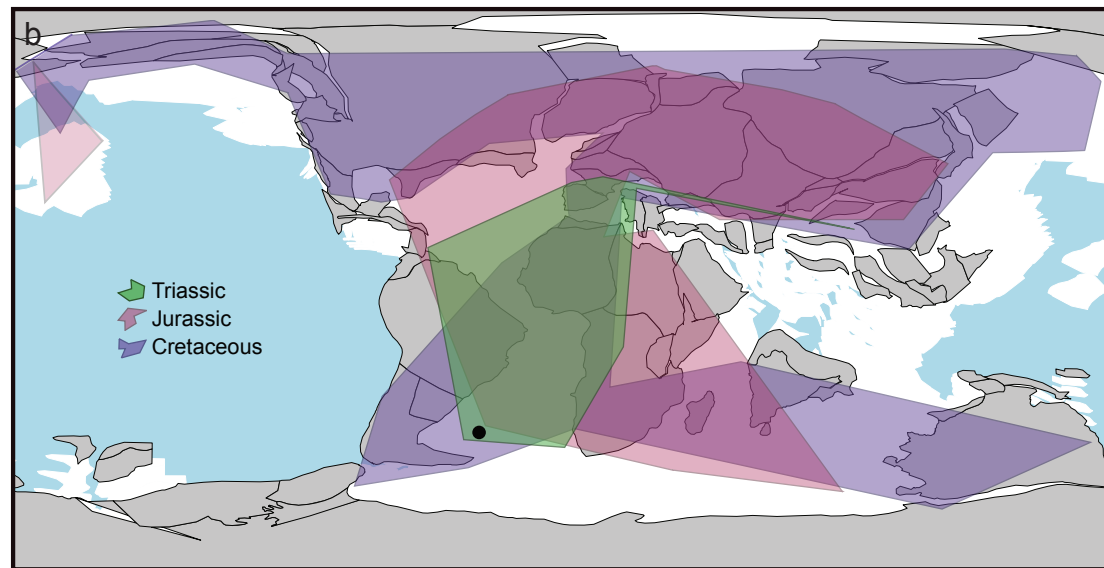
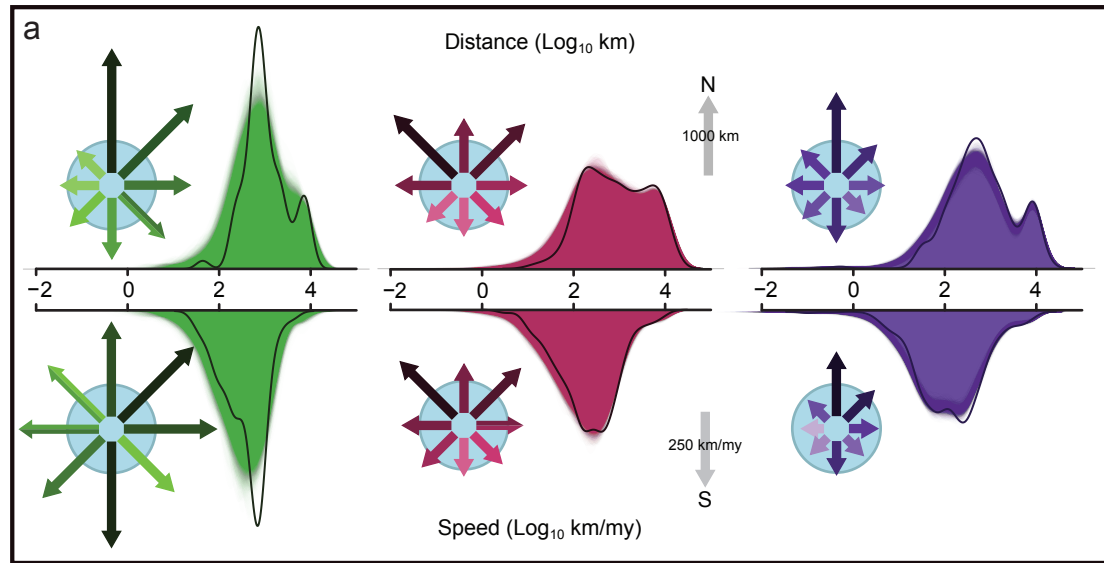

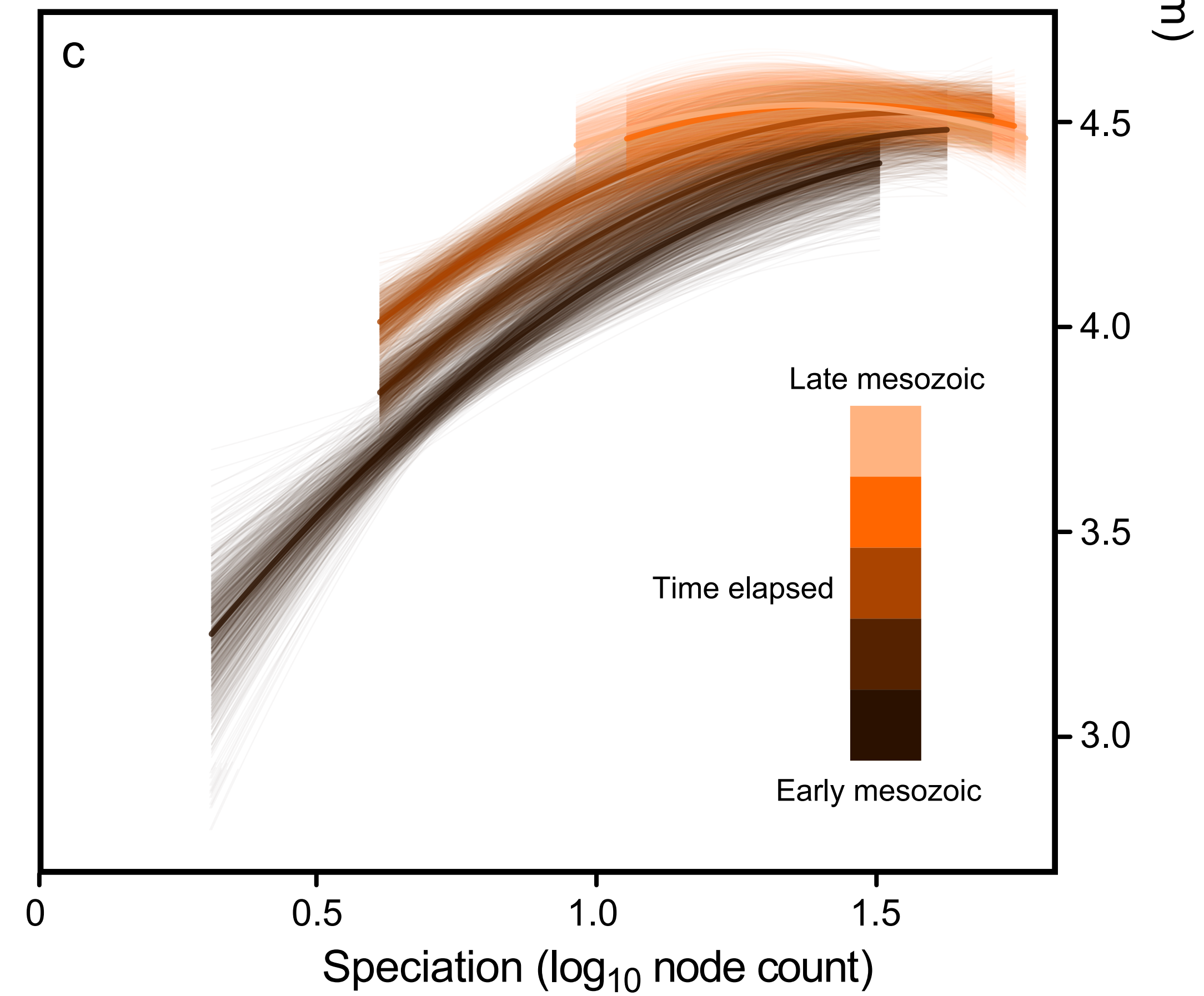
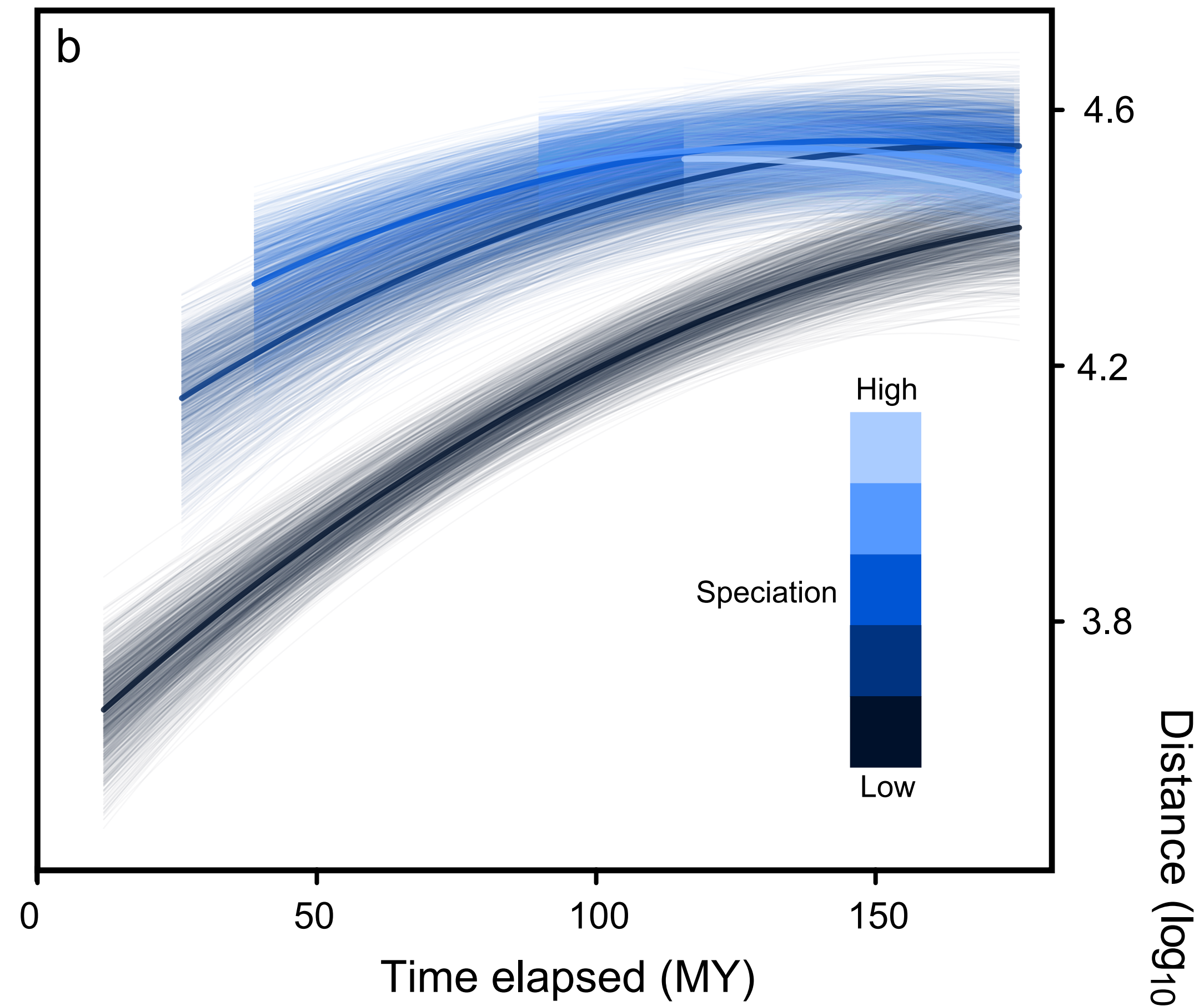

A

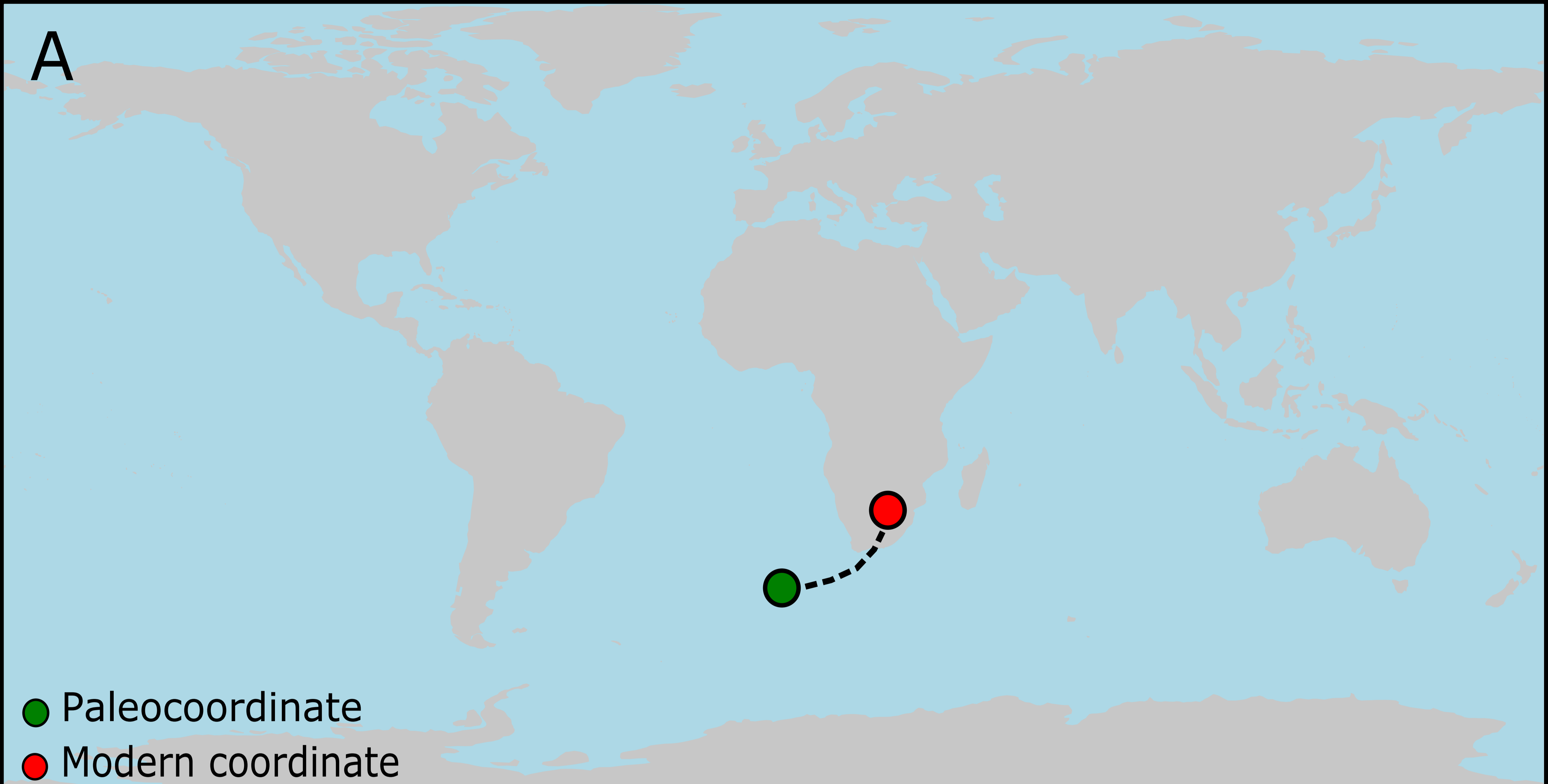

B

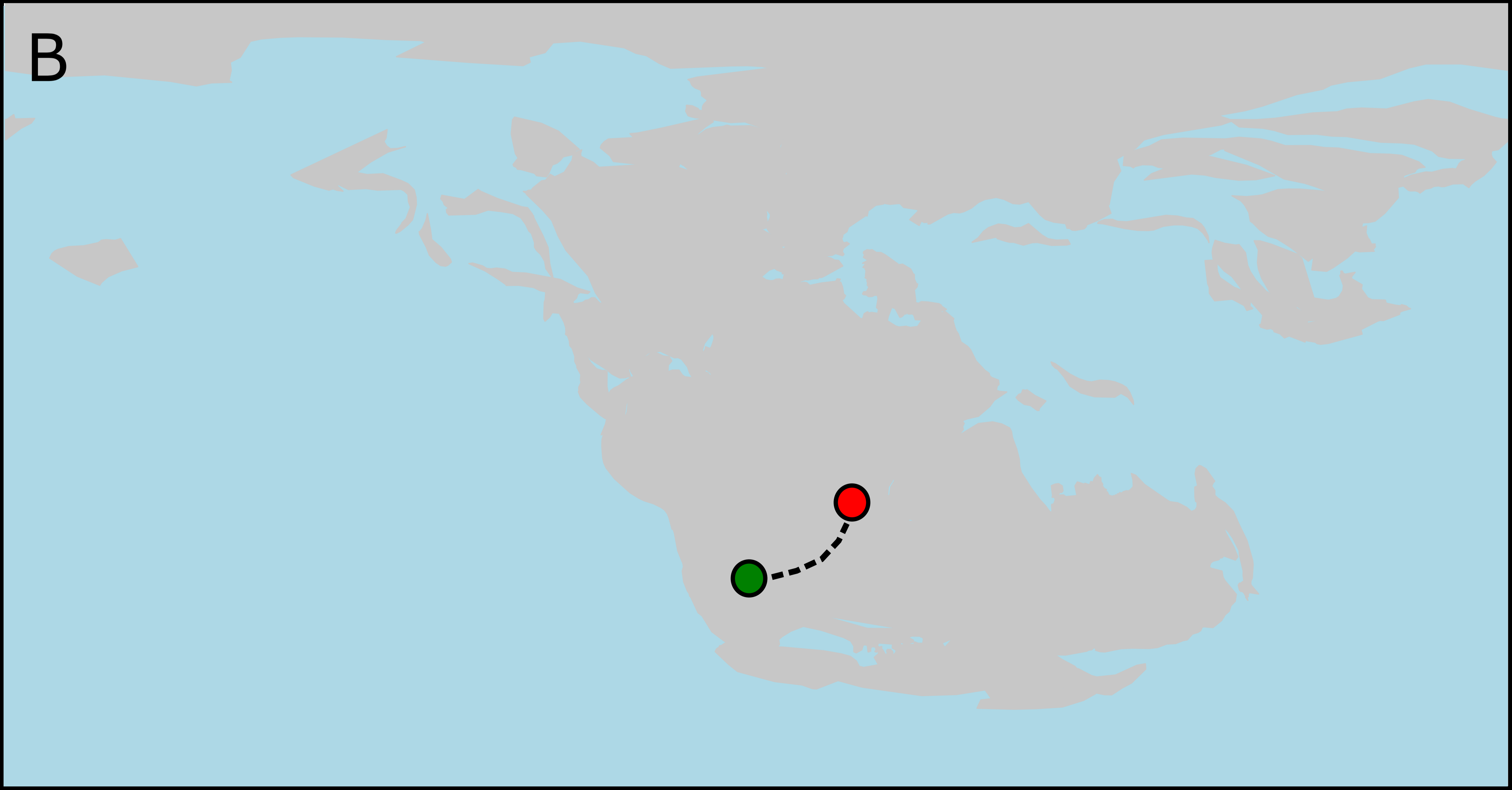

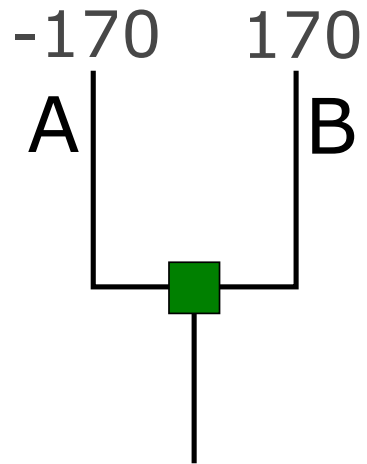

a

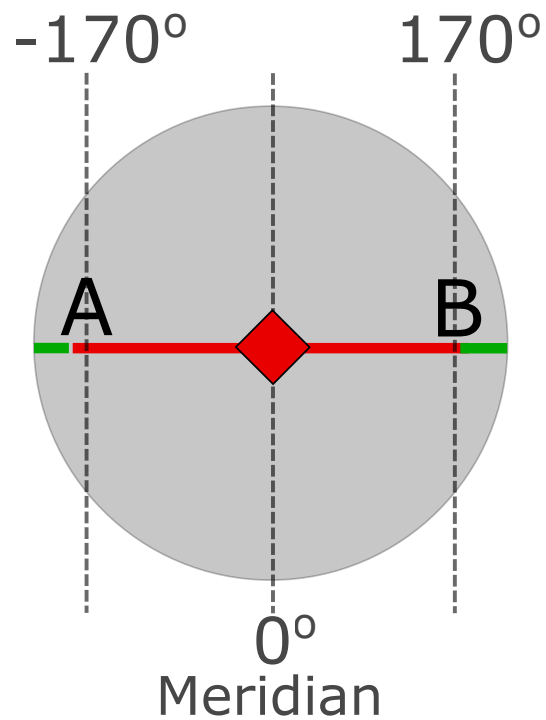

b

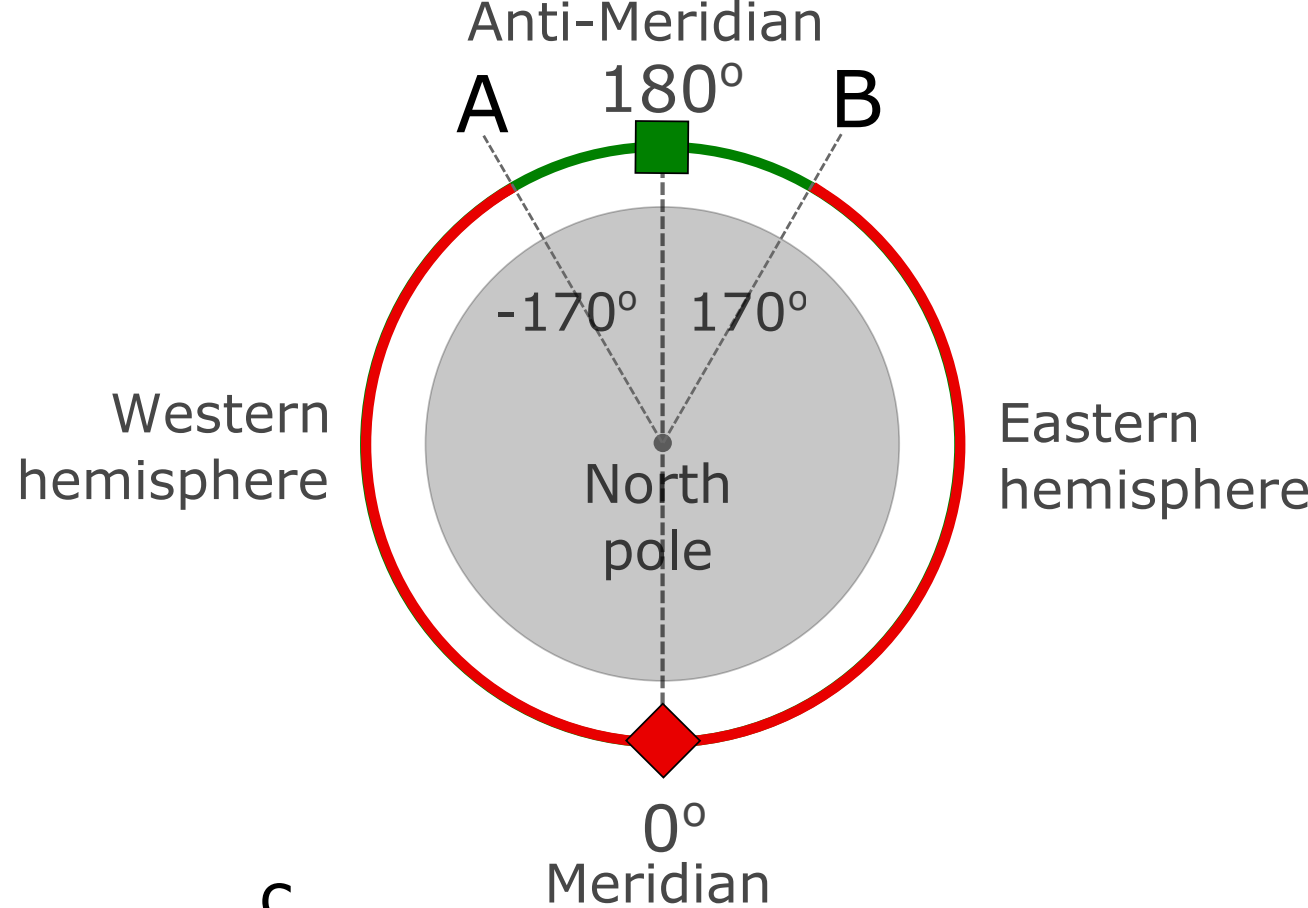

c

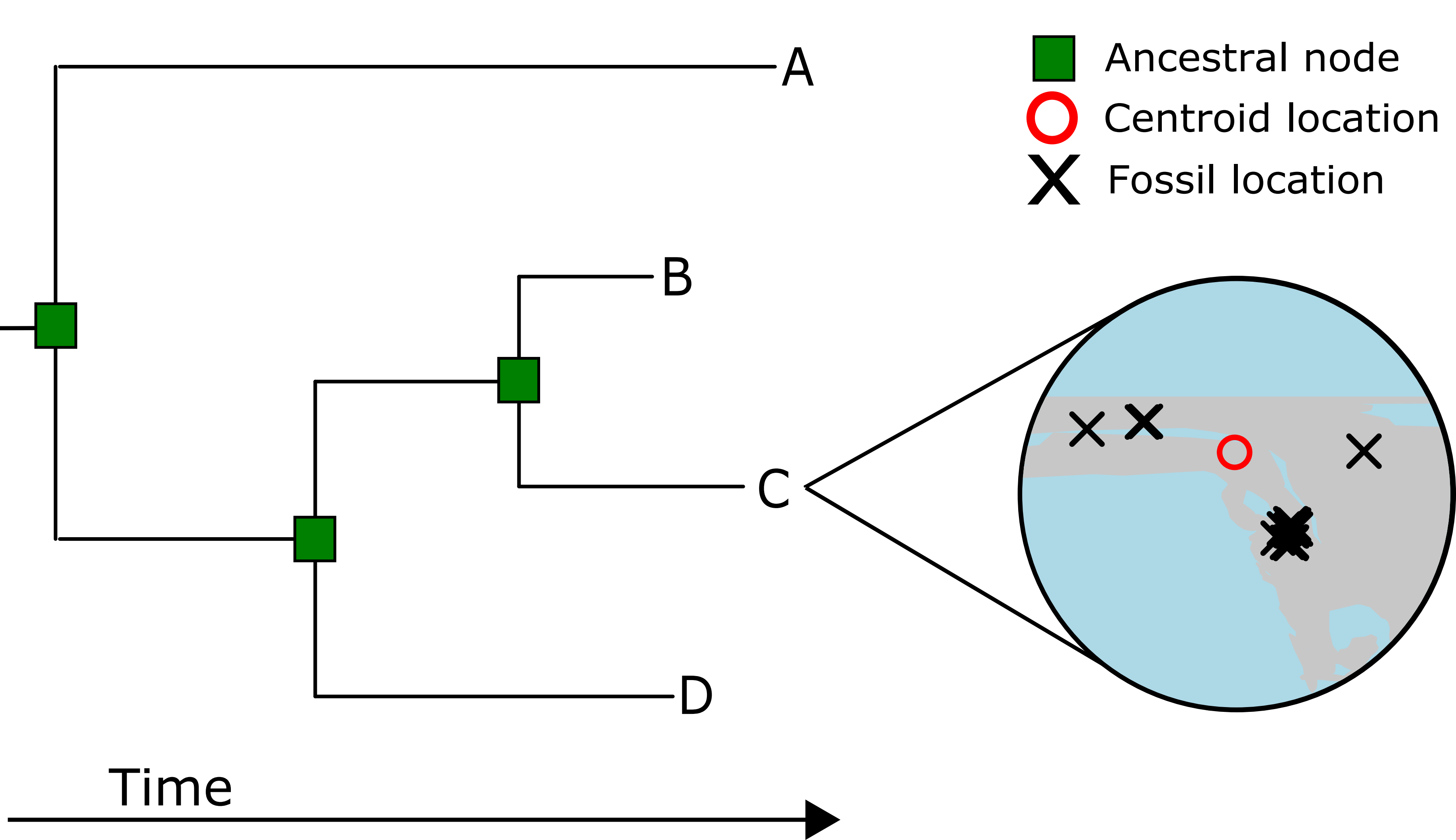

SpeciesName	Diet	Gait
Pisanosaurus_mertii	Not carnivore	Bipedal
Echinodon_becklesii	Not carnivore	Bipedal
Fruitadens_haagarorum	Not carnivore	Bipedal
Tianyulong_confuciusi	Not carnivore	Bipedal
Lycorhinus_angustidens	Not carnivore	Semi-bipedal
Pegomastax_africanus	Not carnivore	Bipedal
Manidens_condorensis	Not carnivore	Bipedal
Abrictosaurus_consors	Not carnivore	Bipedal
Heterodontosaurus_tucki	Not carnivore	Bipedal
Lesothosaurus_diagnosticus	Not carnivore	Bipedal
Scutellosaurus_lawleri	Not carnivore	Semi-bipedal
Emausaurus_ernsti	Not carnivore	Quadrupedal
Scelidosaurus_harrisonii	Not carnivore	Quadrupedal
Chungkingosaurus_jiangbeiensis	Not carnivore	Quadrupedal
Huayangosaurus_taibaii	Not carnivore	Quadrupedal
Dacentrurus_armatus	Not carnivore	Quadrupedal
Kentrosaurus_aethiopicus	Not carnivore	Quadrupedal
Loricatosaurus_priscus	Not carnivore	Quadrupedal
Paranthodon_africanus	Not carnivore	Quadrupedal
Tuojiangosaurus_multispinus	Not carnivore	Quadrupedal
Stegosaurus_mjosi	Not carnivore	Quadrupedal
Stegosaurus_stenops	Not carnivore	Quadrupedal
Stegosaurus_ungulatus	Not carnivore	Quadrupedal
Minmi_paravertebra	Not carnivore	Quadrupedal
Cedarpelta_bilbeyhallorum	Not carnivore	Quadrupedal
Gobisaurus_domoculus	Not carnivore	Quadrupedal
Shamosaurus_scutatus	Not carnivore	Quadrupedal
Tsagantegia_longicranialis	Not carnivore	Quadrupedal
Zhongyuanosaurus_luoyangensis	Not carnivore	Quadrupedal
Crichtonsaurus_bohlini	Not carnivore	Quadrupedal
Crichtonsaurus_benxiensis	Not carnivore	Quadrupedal
Dyoplosaurus_acutesquamous	Not carnivore	Quadrupedal
Pinacosaurus_mephistocephalus	Not carnivore	Quadrupedal
Ankylosaurus_magniventris	Not carnivore	Quadrupedal
Euoplocephalus_tutus	Not carnivore	Quadrupedal
Pinacosaurus_grangeri	Not carnivore	Quadrupedal
Nodocephalosaurus_kirtlandensis	Not carnivore	Quadrupedal
Talarurus_plicatospineus	Not carnivore	Quadrupedal
Tianzhenosaurus_youngi	Not carnivore	Quadrupedal
Saichania_chulsanensis	Not carnivore	Quadrupedal
Tarchia_gigantea	Not carnivore	Quadrupedal
Antarctopelta_oliveroi	Not carnivore	Quadrupedal
Mymoorapelta_maysi	Not carnivore	Quadrupedal
Anoplosaurus_curtonotus	Not carnivore	Quadrupedal
Hylaeosaurus_armatus	Not carnivore	Quadrupedal
Tatankacephalus_cooneyorum	Not carnivore	Quadrupedal
Gargoyleosaurus_parkpinorum	Not carnivore	Quadrupedal
Hoplitosaurus_marshi	Not carnivore	Quadrupedal
Gastonia_burgesi	Not carnivore	Quadrupedal

Peloroplites_cedrimontanus	Not carnivore	Quadrupedal
Polacanthus_foxii	Not carnivore	Quadrupedal
Struthiosaurus_transilvanicus	Not carnivore	Quadrupedal
Zhejiangosaurus_lishuiensis	Not carnivore	Quadrupedal
Hungarosaurus_tormai	Not carnivore	Quadrupedal
Animantarx_ramaljonesei	Not carnivore	Quadrupedal
Niobrarasaurus_coleii	Not carnivore	Quadrupedal
Nodosaurus_textilis	Not carnivore	Quadrupedal
Pawpawsaurus_campbelli	Not carnivore	Quadrupedal
Sauropelta_edwardsi	Not carnivore	Quadrupedal
Silvisaurus_condrayi	Not carnivore	Quadrupedal
Stegopelta_landerensis	Not carnivore	Quadrupedal
Texasetes_pleurohalio	Not carnivore	Quadrupedal
Panoplosaurus_mirus	Not carnivore	Quadrupedal
Edmontonia_longiceps	Not carnivore	Quadrupedal
Edmontonia_rugosidens	Not carnivore	Quadrupedal
Stormbergia_dangershoekii	Not carnivore	Bipedal
Agilisaurus_louderbacki	Not carnivore	Bipedal
Hexinlusaurus_multidens	Not carnivore	Bipedal
Goyocephale_lattimorei	Not carnivore	Bipedal
Homalocephale_calathocercos	Not carnivore	Bipedal
Colepiocephale_lambeii	Not carnivore	Bipedal
Stegoceras_validum	Not carnivore	Bipedal
Stegoceras_novomexicanum	Not carnivore	Bipedal
Amtocephale_gobiensis	Not carnivore	Bipedal
Prenocephale_prenesi	Not carnivore	Bipedal
Tylocephale_gilmorei	Not carnivore	Bipedal
Hanssuesia_sternbergi	Not carnivore	Bipedal
Pachycephalosaurus_wyomingensis	Not carnivore	Bipedal
Yinlong_downsi	Not carnivore	Semi-bipedal
Micropachycephalosaurus_hongtuyanensis	Not carnivore	Bipedal
Chaoyangsaurus_youngi	Not carnivore	Semi-bipedal
Xuanhuaceratops_niei	Not carnivore	Semi-bipedal
Psittacosaurus_mongoliensis	Not carnivore	Semi-bipedal
Psittacosaurus_neimongoliensis	Not carnivore	Semi-bipedal
Psittacosaurus_sinensis	Not carnivore	Semi-bipedal
Psittacosaurus_gobiensis	Not carnivore	Semi-bipedal
Liaoceratops_yanzigouensis	Not carnivore	Semi-bipedal
Yamaceratops_dorngobiensis	Not carnivore	Semi-bipedal
Archaeoceratops_oshimai	Not carnivore	Quadrupedal
Archaeoceratops_yujingziensis	Not carnivore	Semi-bipedal
Koreaceratops_hwaseongensis	Not carnivore	Quadrupedal
Asiaceratops_salsopaludalis	Not carnivore	Quadrupedal
Cerasinops_hodgskissi	Not carnivore	Quadrupedal
Montanoceratops_cerorynchus	Not carnivore	Quadrupedal
Prenoceratops_pieganensis	Not carnivore	Quadrupedal
Leptoceratops_gracilis	Not carnivore	Bipedal
Udanoceratops_tschizhovi	Not carnivore	Quadrupedal
Zhuchengceratops_inexpectus	Not carnivore	Semi-bipedal
Gryphoceratops_morrisoni	Not carnivore	Semi-bipedal

Unescoceratops_koppelhusae	Not carnivore	Bipedal
Graciliceratops_mongoliensis	Not carnivore	Quadrupedal
Bagaceratops_rozhdestvenskyi	Not carnivore	Quadrupedal
Protoceratops_andrewsi	Not carnivore	Quadrupedal
Turanoceratops_tardabilis	Not carnivore	Quadrupedal
Zuniceratops_christopheri	Not carnivore	Quadrupedal
Diabloceratops_eatoni	Not carnivore	Quadrupedal
Albertaceratops_nesmoi	Not carnivore	Quadrupedal
Centrosaurus_apertus	Not carnivore	Quadrupedal
Spinops_sternbergorum	Not carnivore	Quadrupedal
Styracosaurus_albertensis	Not carnivore	Quadrupedal
Centrosaurus_brinkmani	Not carnivore	Quadrupedal
Rubeosaurus_ovatus	Not carnivore	Quadrupedal
Einiosaurus_procurvicornis	Not carnivore	Quadrupedal
Achelousaurus_horneri	Not carnivore	Quadrupedal
Pachyrhinosaurus_lakustai	Not carnivore	Quadrupedal
Pachyrhinosaurus_canadensis	Not carnivore	Quadrupedal
Pachyrhinosaurus_perotorum	Not carnivore	Quadrupedal
Chasmosaurus_russelli	Not carnivore	Quadrupedal
Chasmosaurus_belli	Not carnivore	Quadrupedal
Agujaceratops_mariscalensis	Not carnivore	Quadrupedal
Pentaceratops_sternbergii	Not carnivore	Quadrupedal
Utahceratops_gettyi	Not carnivore	Quadrupedal
Coahuilaceratops_magnacuerna	Not carnivore	Quadrupedal
Kosmoceratops_richardsoni	Not carnivore	Quadrupedal
Vagaceratops_irvinensis	Not carnivore	Quadrupedal
Anchiceratops_ornatus	Not carnivore	Quadrupedal
Arrhinoceratops_brachyops	Not carnivore	Quadrupedal
Eotriceratops_xerinsularis	Not carnivore	Quadrupedal
Ojoceratops_fowleri	Not carnivore	Quadrupedal
Torosaurus_latus	Not carnivore	Quadrupedal
Triceratops_horridus	Not carnivore	Quadrupedal
Triceratops_prorsus	Not carnivore	Quadrupedal
Gideonmantellia_amosanjuanae	Not carnivore	Bipedal
Oryctodromeus_cubicularis	Not carnivore	Bipedal
Koreanosaurus_boseongensis	Not carnivore	Semi-bipedal
Orodromeus_makelai	Not carnivore	Bipedal
Zephyrosaurus_schaffi	Not carnivore	Bipedal
Parksosaurus_warreni	Not carnivore	Bipedal
Thescelosaurus_neglectus	Not carnivore	Bipedal
Thescelosaurus_assiniboiensis	Not carnivore	Bipedal
Jeholosaurus_shangyuanensis	Not carnivore	Bipedal
Changchunsaurus_parvus	Not carnivore	Bipedal
Haya_griva	Not carnivore	Bipedal
Hypsilophodon_foxi	Not carnivore	Bipedal
Gasparinisaura_cincosaltensis	Not carnivore	Bipedal
Anabisetia_saldiviai	Not carnivore	Bipedal
Macrogyphosaurus_gondwanicus	Not carnivore	Bipedal
Talenkauen_santacruzensis	Not carnivore	Semi-bipedal
Muttaburrasaurus_langdoni	Not carnivore	Semi-bipedal

Rhabdodon_priscum	Not carnivore	Semi-bipedal
Zalmoxes_robustus	Not carnivore	Semi-bipedal
Zalmoxes_shqiperorum	Not carnivore	Semi-bipedal
Mochlodon_suessi	Not carnivore	Semi-bipedal
Mochlodon_vorosi	Not carnivore	Semi-bipedal
Tenontosaurus_tilletti	Not carnivore	Semi-bipedal
Tenontosaurus_dossi	Not carnivore	Semi-bipedal
Callovosaurus_leedsi	Not carnivore	Semi-bipedal
Dryosaurus_altus	Not carnivore	Bipedal
Dysalotosaurus_lettowvorbecki	Not carnivore	Bipedal
Kangnasaurus_coetzei	-	-
Valdosaurus_canaliculatus	Not carnivore	Bipedal
Camptosaurus_dispar	Not carnivore	Semi-bipedal
Cumnoria_prestwichii	Not carnivore	Semi-bipedal
Uteodon_aphanoecetes	Not carnivore	Semi-bipedal
Hippodraco_scutodens	Not carnivore	Semi-bipedal
Theiophytalia_kerri	Not carnivore	Semi-bipedal
Cedarorestes_crichtoni	Not carnivore	Semi-bipedal
Dakotadon_lakotaensis	Not carnivore	Semi-bipedal
Iguanacolossus_fortis	Not carnivore	Semi-bipedal
Lanzhousaurus_magnidens	Not carnivore	Semi-bipedal
Barilium_dawsoni	Not carnivore	Semi-bipedal
Iguanodon_bernissartensis	Not carnivore	Semi-bipedal
Ouranosaurus_nigeriensis	Not carnivore	Semi-bipedal
Mantellisaurus_atherfieldensis	Not carnivore	Semi-bipedal
Jinzhousaurus_yangi	Not carnivore	Semi-bipedal
Penelopognathus_weishampeli	Not carnivore	Semi-bipedal
Altirhinus_kurzanovi	Not carnivore	Semi-bipedal
Equijubus_normani	Not carnivore	Semi-bipedal
Probactrosaurus_mazongshanensis	Not carnivore	Semi-bipedal
Eolambia_caroljonasa	Not carnivore	Semi-bipedal
Probactrosaurus_gobiensis	Not carnivore	Semi-bipedal
Jeyawati_rugoculus	Not carnivore	Semi-bipedal
Protohadros_byrdi	Not carnivore	Semi-bipedal
Tethyshadros_insularis	Not carnivore	Semi-bipedal
Nanyangosaurus_zhugeii	Not carnivore	Semi-bipedal
Tanius_sinensis	Not carnivore	Semi-bipedal
Gilmoreosaurus_mongolensis	Not carnivore	Semi-bipedal
Bactrosaurus_johnsoni	Not carnivore	Semi-bipedal
Shuangmiaosaurus_gilmorei	Not carnivore	Semi-bipedal
Claosaurus_agilis	Not carnivore	Semi-bipedal
Telmatosaurus_transsylvanicus	Not carnivore	Semi-bipedal
Lophorhodon_atopus	Not carnivore	Semi-bipedal
Wulagasaurus_dongi	Not carnivore	Semi-bipedal
Acristavus_gagslarsoni	Not carnivore	Semi-bipedal
Brachylophosaurus_canadensis	Not carnivore	Semi-bipedal
Maiasaura_peeblesorum	Not carnivore	Semi-bipedal
Barsboldia_sicinskii	Not carnivore	Semi-bipedal
Kritosaurus_navajovius	Not carnivore	Semi-bipedal
Gryposaurus_notabilis	Not carnivore	Semi-bipedal

Gryposaurus_monumentensis	Not carnivore	Semi-bipedal
Gryposaurus_latidens	Not carnivore	Semi-bipedal
Secernosaurus_koernerii	Not carnivore	Semi-bipedal
Willinakaqe_salitralensis	Not carnivore	Semi-bipedal
Prosaurolophus_maximus	Not carnivore	Semi-bipedal
Saurolophus_osborni	Not carnivore	Semi-bipedal
Saurolophus_angustirostris	Not carnivore	Semi-bipedal
Kerberosaurus_manakini	Not carnivore	Semi-bipedal
Kundurosaurus_nagornyii	Not carnivore	Semi-bipedal
Shantungosaurus_giganteus	Not carnivore	Semi-bipedal
Edmontosaurus_annectens	Not carnivore	Semi-bipedal
Edmontosaurus_regalis	Not carnivore	Semi-bipedal
Aralosaurus_tuberiferus	Not carnivore	Semi-bipedal
Pararhabdodon_isonensis	Not carnivore	Semi-bipedal
Tsintaosaurus_spinorhinus	Not carnivore	Semi-bipedal
Jaxartosaurus_aralensis	Not carnivore	Semi-bipedal
Arenysaurus_ardevoli	Not carnivore	Semi-bipedal
Blasisaurus_canudoii	Not carnivore	Semi-bipedal
Charonosaurus_jiayinensis	Not carnivore	Semi-bipedal
Parasaurolophus_walkerii	Not carnivore	Semi-bipedal
Parasaurolophus_cyrtoctristatus	Not carnivore	Semi-bipedal
Amurosaurus_riabinini	Not carnivore	Semi-bipedal
Sahaliyana_elunchunorum	Not carnivore	Semi-bipedal
Magnapaulia_laticaudus	Not carnivore	Semi-bipedal
Lambeosaurus_lambeii	Not carnivore	Semi-bipedal
Lambeosaurus_magnicristatus	Not carnivore	Semi-bipedal
Corythosaurus_casuarius	Not carnivore	Semi-bipedal
Olorotitan_arharensis	Not carnivore	Semi-bipedal
Hypacrosaurus_altispinus	Not carnivore	Semi-bipedal
Hypacrosaurus_stebingeri	Not carnivore	Semi-bipedal
Pampdromaeus	Not carnivore	Bipedal
Saturnalia	Not carnivore	Bipedal
Chromogisaurus	Not carnivore	Quadrupedal
Pantydraco	Not carnivore	Bipedal
Arcusaurus	Not carnivore	Semi-bipedal
Thecodontosaurus	Not carnivore	Bipedal
Efraasia	Not carnivore	Semi-bipedal
Plateosaurus	Not carnivore	Semi-bipedal
Ruehleia	Not carnivore	Semi-bipedal
Plateosaurus_engelhardti	Not carnivore	Semi-bipedal
Unaysaurus	Not carnivore	Semi-bipedal
Riojasaurus	Not carnivore	Semi-bipedal
Eucnemesaurus	Not carnivore	Semi-bipedal
Sarhsaurus	Not carnivore	Quadrupedal
Massospondylus	Not carnivore	Semi-bipedal
Leyesaurus	Not carnivore	Semi-bipedal
Adeopapposaurus	Not carnivore	Semi-bipedal
Coloradisaurus	Not carnivore	Semi-bipedal
Glacialisaurus	Not carnivore	Quadrupedal
Lufengosaurus	Not carnivore	Semi-bipedal

Jingshanosaurus	Not carnivore	Semi-bipedal
Yunnanosaurus_huangi	Not carnivore	Semi-bipedal
Chuxiongosaurus	Not carnivore	Semi-bipedal
Seitaad	Not carnivore	Quadrupedal
Anchisaurus	Not carnivore	Semi-bipedal
Aardonyx	Not carnivore	Semi-bipedal
Leoneosaurus	Not carnivore	Semi-bipedal
Melanorosaurus	Not carnivore	Quadrupedal
Antetonitrus	Not carnivore	Quadrupedal
Lessemsaurus	Not carnivore	Semi-bipedal
Lamplughsaura	Not carnivore	Quadrupedal
Camelotia	Not carnivore	Quadrupedal
Gongxianosaurus	Not carnivore	Quadrupedal
Isanosaurus	Not carnivore	Quadrupedal
Tazoudasaurus	Not carnivore	Quadrupedal
Vulcanodon	Not carnivore	Quadrupedal
Rhoetosaurus	Not carnivore	Quadrupedal
Kotasaurus	Not carnivore	Quadrupedal
Spinophorosaurus	Not carnivore	Quadrupedal
Shunosaurus	Not carnivore	Quadrupedal
Datousaurus	Not carnivore	Quadrupedal
Cetiosaurus	Not carnivore	Quadrupedal
Patagosaurus	Not carnivore	Quadrupedal
Barapasaurus	Not carnivore	Quadrupedal
Klamelisaurus	Not carnivore	Quadrupedal
Chuanjiesaurus	Not carnivore	Quadrupedal
Mamenchisaurus_youngi	Not carnivore	Quadrupedal
Mamenchisaurus_constructus	Not carnivore	Quadrupedal
Yuanmousaurus_jiangyiensis	Not carnivore	Quadrupedal
Cetiosauriscus	Not carnivore	Quadrupedal
Omeisaurus_junghsiensis	Not carnivore	Quadrupedal
Omeisaurus_jiaoi	Not carnivore	Quadrupedal
Omeisaurus_maoanus	Not carnivore	Quadrupedal
Omeisaurus_tianfuensis	Not carnivore	Quadrupedal
Ferganasaurus	Not carnivore	Quadrupedal
Turiasaurus	Not carnivore	Quadrupedal
Jobaria	Not carnivore	Quadrupedal
Atlasaurus	Not carnivore	Quadrupedal
Haplocanthosaurus_priscus	Not carnivore	Quadrupedal
Amphicoelias	Not carnivore	Quadrupedal
Nigersaurus	Not carnivore	Quadrupedal
Demandasaurus	Not carnivore	Quadrupedal
Cathartesaura	Not carnivore	Quadrupedal
Limaysaurus	Not carnivore	Quadrupedal
Zapalasaurus	Not carnivore	Quadrupedal
Rebbachisaurus	Not carnivore	Quadrupedal
Comahuesaurus	Not carnivore	Quadrupedal
Dicraeosaurus_sattleri	Not carnivore	Quadrupedal
Brachytrachelopan	Not carnivore	Quadrupedal
Amargasaurus	Not carnivore	Quadrupedal

Suuwassea	Not carnivore	Quadrupedal
Apatosaurus_ajax	Not carnivore	Quadrupedal
Apatosaurus_excelsus	Not carnivore	Quadrupedal
Apatosaurus_louisae	Not carnivore	Quadrupedal
Tornieria	Not carnivore	Quadrupedal
Barosaurus	Not carnivore	Quadrupedal
Diplodocus_carnegiei	Not carnivore	Quadrupedal
Diplodocus_hayi	Not carnivore	Quadrupedal
Diplodocus_hallorum	Not carnivore	Quadrupedal
Diplodocus_longus	Not carnivore	Quadrupedal
Lourinhasaurus	Not carnivore	Quadrupedal
Camarasaurus_lewisi	Not carnivore	Quadrupedal
Camarasaurus_supremus	Not carnivore	Quadrupedal
Camarasaurus_grandis	Not carnivore	Quadrupedal
Janenschia	Not carnivore	Quadrupedal
Tehuelchesaurus	Not carnivore	Quadrupedal
Aragosaurus	Not carnivore	Quadrupedal
Galveosaurus	Not carnivore	Quadrupedal
Europasaurus	Not carnivore	Quadrupedal
Brachiosaurus	Not carnivore	Quadrupedal
Lusotitan	Not carnivore	Quadrupedal
Giraffatitan	Not carnivore	Quadrupedal
Cedarosaurus	Not carnivore	Quadrupedal
Venenosaurus	Not carnivore	Quadrupedal
Dongbeititan	Not carnivore	Quadrupedal
Sauroposeidon	Not carnivore	Quadrupedal
Sonorasaurus	Not carnivore	Quadrupedal
Tastavinsaurus	Not carnivore	Quadrupedal
Pelorosaurus_becklesii	Not carnivore	Quadrupedal
Euhelopus	Not carnivore	Quadrupedal
Erketu	Not carnivore	Quadrupedal
Qiaowanlong	Not carnivore	Quadrupedal
Gobititan	Not carnivore	Quadrupedal
Tangvayosaurus	Not carnivore	Quadrupedal
Phuwiangosaurus	Not carnivore	Quadrupedal
Chubutisaurus	Not carnivore	Quadrupedal
Ruyangosaurus	Not carnivore	Quadrupedal
Wintonotitan	Not carnivore	Quadrupedal
Ligabuesaurus	Not carnivore	Quadrupedal
Andesaurus	Not carnivore	Quadrupedal
Futalognkosaurus	Not carnivore	Quadrupedal
Mendozasaurus	Not carnivore	Quadrupedal
Argentinosaurus	Not carnivore	Quadrupedal
Epachthosaurus	Not carnivore	Quadrupedal
Malawisaurus	Not carnivore	Quadrupedal
Nemegtosaurus	Not carnivore	Quadrupedal
Isisaurus	Not carnivore	Quadrupedal
Tapuiasaurus	Not carnivore	Quadrupedal
Gondwanatitan	Not carnivore	Quadrupedal
Aeolosaurus_maximus	Not carnivore	Quadrupedal

Aeolosaurus_sp.	Not carnivore	Quadrupedal
Aeolosaurus_rionegrinus	Not carnivore	Quadrupedal
Muyelensaurus	Not carnivore	Quadrupedal
Rinconosaurus	Not carnivore	Quadrupedal
Alamosaurus	Not carnivore	Quadrupedal
Opisthocoelicaudia	Not carnivore	Quadrupedal
Rocasaurus	Not carnivore	Quadrupedal
Neuquensaurus	Not carnivore	Quadrupedal
Saltasaurus	Not carnivore	Quadrupedal
Herrerasaurus	Carnivore	Bipedal
Staurikosaurus	Carnivore	Bipedal
Eoraptor	Carnivore	Bipedal
Daemonosaurus	Carnivore	Bipedal
Tawa	Carnivore	Bipedal
Skayentakatae	Carnivore	Bipedal
Coelophysis_bauri	Carnivore	Bipedal
Coelophysis_rhodesiensis	Carnivore	Bipedal
Liliensternus	Carnivore	Bipedal
Zupaysaurus	Carnivore	Bipedal
Dilophosaurus	Carnivore	Bipedal
Spinostropheus	Carnivore	Bipedal
Elaphrosaurus	Carnivore	Bipedal
Limusaurus	Carnivore	Bipedal
Ceratosaurus	Carnivore	Bipedal
Genyodectes	Carnivore	Bipedal
Masiakasaurus	Carnivore	Bipedal
Genusaurus	Carnivore	Bipedal
Noasaurus	Carnivore	Bipedal
Velocisaurus	Carnivore	Bipedal
Laevisuchus	Carnivore	Bipedal
Eoabelisaurus	Carnivore	Bipedal
Rugops	Carnivore	Bipedal
Abelisaurus	Carnivore	Bipedal
Indosaurus	Carnivore	Bipedal
Majungasaurus	Carnivore	Bipedal
Rajasaurus	Carnivore	Bipedal
Aucasaurus	Carnivore	Bipedal
Carnotaurus	Carnivore	Bipedal
Ekrixinatosaurus	Carnivore	Bipedal
Skorpiovenator	Carnivore	Bipedal
Ilokelesia	Carnivore	Bipedal
Cryolophosaurus	Carnivore	Bipedal
D_sinensis	Carnivore	Bipedal
Monolophosaurus	Carnivore	Bipedal
Marshosaurus	Carnivore	Bipedal
Condorraptor	Carnivore	Bipedal
Piatnizkysaurus	Carnivore	Bipedal
Spinosaurus	Carnivore	Bipedal
Angaturama	Carnivore	Bipedal
Irritator	Carnivore	Bipedal

Suchomimus	Carnivore	Bipedal
Baryonyx	Carnivore	Bipedal
Eustreptospondylus	Carnivore	Bipedal
Afrovenator	Carnivore	Bipedal
Magnosaurus	Carnivore	Bipedal
Dubreuillosaurus	Carnivore	Bipedal
Leshansaurus	Carnivore	Bipedal
Piveaeausaurus	Carnivore	Bipedal
Duriavenator	Carnivore	Bipedal
Megalosaurus	Carnivore	Bipedal
Torvosaurus	Carnivore	Bipedal
Shidaisaurus	Carnivore	Bipedal
Metriacanthosaurus	Carnivore	Bipedal
Sinraptor_hepingensis	Carnivore	Bipedal
Sinraptor_dongi	Carnivore	Bipedal
Siamotyrannus	Carnivore	Bipedal
Yangchuanosaurus_zigongensis	Carnivore	Bipedal
Yangchuanosaurus_magnus	Carnivore	Bipedal
Allosaurus	Carnivore	Bipedal
Saurophaganax	Carnivore	Bipedal
Neovenator	Carnivore	Bipedal
Chilantaisaurus	Carnivore	Bipedal
Aerosteon	Carnivore	Bipedal
Megaraptor	Carnivore	Bipedal
Australovenator	Carnivore	Bipedal
Fukuiraptor	Carnivore	Bipedal
Eocarcharia	Carnivore	Bipedal
Concavenator	Carnivore	Bipedal
Acrocanthosaurus	Carnivore	Bipedal
Shaochilong	Carnivore	Bipedal
Tyrannotitan	Carnivore	Bipedal
Carcharodontosaurus	Carnivore	Bipedal
Giganotosaurus	Carnivore	Bipedal
Mapusaurus	Carnivore	Bipedal
Zuolong	Carnivore	Bipedal
Tanycolagreus	Carnivore	Bipedal
Guanlong	Carnivore	Bipedal
Proceratosaurus	Carnivore	Bipedal
Sinotyrannus	Carnivore	Bipedal
Dilong	Carnivore	Bipedal
Stokesosaurus	Carnivore	Bipedal
Eotyrannus	Carnivore	Bipedal
Xiongguanlong	Carnivore	Bipedal
Dryptosaurus	Carnivore	Bipedal
Appalachiosaurus	Carnivore	Bipedal
Bistahieversor	Carnivore	Bipedal
Albertosaurus	Carnivore	Bipedal
Gorgosaurus	Carnivore	Bipedal
Alioramus	Carnivore	Bipedal
Teratophoneus	Carnivore	Bipedal

Daspletosaurus	Carnivore	Bipedal
Tarbosaurus	Carnivore	Bipedal
Tyrannosaurus	Carnivore	Bipedal
Nqwebasaurus	Not carnivore	Bipedal
Pelecanimimus	Not carnivore	Bipedal
Hexing	Not carnivore	Bipedal
Shenzhousaurus	Carnivore	Bipedal
Harpymimus	Not carnivore	Bipedal
Beishanlong	Not carnivore	Bipedal
Garudimimus	Not carnivore	Bipedal
Archaeornithomimus	Not carnivore	Bipedal
Sinornithomimus	Carnivore	Bipedal
Gallimimus	Not carnivore	Bipedal
Anserimimus	Not carnivore	Bipedal
Struthiomimus	Not carnivore	Bipedal
Ornithomimus	Not carnivore	Bipedal
Ornitholestes	Carnivore	Bipedal
Sinosauropteryx	Carnivore	Bipedal
Huixagnathus	Carnivore	Bipedal
Compsognathus	Carnivore	Bipedal
Haplocheirus	Not carnivore	Bipedal
Patagonykus	Not carnivore	Bipedal
Alvarezsaurus	Not carnivore	Bipedal
Parvicursor	Not carnivore	Bipedal
Mononykus	Not carnivore	Bipedal
Shuvuuia	Not carnivore	Bipedal
Incisivosaurus	Not carnivore	Bipedal
Caudipteryx	Not carnivore	Bipedal
Protarchaeopteryx	Not carnivore	Bipedal
Similicaudipteryx	Not carnivore	Bipedal
Avimimus	Not carnivore	Bipedal
Microvenator	Not carnivore	Bipedal
Gigantoraptor	Not carnivore	Bipedal
Caenagnathasia	Not carnivore	Bipedal
Elmisaurus	Not carnivore	Bipedal
Leptorhynchos	Not carnivore	Bipedal
Hagryphus	Not carnivore	Bipedal
Chirostenotes	Not carnivore	Bipedal
Caenagnathus	Not carnivore	Bipedal
Oviraptor	Not carnivore	Bipedal
Citipati	Not carnivore	Bipedal
Khaan	Not carnivore	Bipedal
Conchoraptor	Not carnivore	Bipedal
Machairasaurus	Not carnivore	Bipedal
Nemegtomaia	Not carnivore	Bipedal
Heyuannia	Not carnivore	Bipedal
Ingenia	Not carnivore	Bipedal
Falcarius	Not carnivore	Bipedal
Alxasaurus	Not carnivore	Bipedal
Erliansaurus	Not carnivore	Bipedal

Neimongosaurus	Not carnivore	Bipedal
Suzhousaurus	Not carnivore	Bipedal
Nanshiungosaurus	Not carnivore	Bipedal
Erlikosaurus	Not carnivore	Bipedal
Therizinosaurus	Not carnivore	Bipedal
Nothronychus_graffami	Not carnivore	Bipedal
Nothronychus_mckinleyi	Not carnivore	Bipedal
Epidexipteryx	Carnivore	Bipedal
Anchiornis	Carnivore	Bipedal
Xiaotingia	Carnivore	Bipedal
Jinfengopteryx	Carnivore	Bipedal
Mei	Carnivore	Bipedal
Sinovenator	Carnivore	Bipedal
Xixiasaurus	Carnivore	Bipedal
Byronosaurus	Carnivore	Bipedal
Sinornithoides	Carnivore	Bipedal
Troodon	Carnivore	Bipedal
Linhevenator	Carnivore	Bipedal
Saurornithoides	Carnivore	Bipedal
Zanzabazaar	Carnivore	Bipedal
Makhala	Carnivore	Bipedal
Rahonavis	Carnivore	Bipedal
Buitreraptor	Carnivore	Bipedal
Unenlagia	Carnivore	Bipedal
Austroraptor	Carnivore	Bipedal
Shanag	Carnivore	Bipedal
Microraptor_zhaoianus	Carnivore	Bipedal
Microraptor_gui	Carnivore	Bipedal
Hesperonychus	Carnivore	Bipedal
Graciliraptor	Carnivore	Bipedal
Sinornithosaurus	Carnivore	Bipedal
Tianyuraptor	Carnivore	Bipedal
Dromaeosaurus	Carnivore	Bipedal
Achillobator	Carnivore	Bipedal
Utahraptor	Carnivore	Bipedal
Atrociraptor	Carnivore	Bipedal
Bambiraptor	Carnivore	Bipedal
Tsaagan	Carnivore	Bipedal
Saurornitholestes	Carnivore	Bipedal
Balaur	Carnivore	Bipedal
Velociraptor	Carnivore	Bipedal
Deinonychus	Carnivore	Bipedal
Archaeopteryx	Carnivore	Bipedal
Sapeornis	Carnivore	Bipedal
Jeholornis	Carnivore	Bipedal
Jixianornis	Carnivore	Bipedal
Zhongornis	Carnivore	Bipedal
Eoconfuciusornis	Carnivore	Bipedal
Changchengornis	Carnivore	Bipedal
Confuciusornis_sanctus	Carnivore	Bipedal

Confuciusornis_wei	Carnivore	Bipedal
Jinzhourornis_zhangjiyingia	Carnivore	Bipedal
Protopteryx	Carnivore	Bipedal
Otogornis	Carnivore	Bipedal
Elsornis	Carnivore	Bipedal
Shenqiornis	Carnivore	Bipedal
Longipteryx	Carnivore	Bipedal
Boluochia	Carnivore	Bipedal
Rapaxavis	Carnivore	Bipedal
Iberomesornis	Carnivore	Bipedal
Shanweinia	Carnivore	Bipedal
Longirostravis	Carnivore	Bipedal
Vescornis	Carnivore	Bipedal
Pengornis	Carnivore	Bipedal
Gobipteryx	Carnivore	Bipedal
Neuquenornis	Carnivore	Bipedal
Eoenantiornis	Carnivore	Bipedal
Concornis	Carnivore	Bipedal
Eocathayornis	Carnivore	Bipedal
Cathayornis	Carnivore	Bipedal
Liaoningornis	Not carnivore	Bipedal
Eoalulavis	Carnivore	Bipedal
Archaeorhynchus	Carnivore	Bipedal
Patagopteryx	Not carnivore	Bipedal
Jianchangornis	Carnivore	Bipedal
Schizooura	Carnivore	Bipedal
Vorona	Carnivore	Bipedal
Zhongjianornis	Carnivore	Bipedal
Chaoyangia	Carnivore	Bipedal
Hongshanornis	Carnivore	Bipedal
Longicrusavis	Carnivore	Bipedal
Yixianornis	Carnivore	Bipedal
Yanornis	Carnivore	Bipedal
Songlingornis	Carnivore	Bipedal
Gansus	Carnivore	Bipedal
Apsaravis	Carnivore	Bipedal
Ambiortus	Carnivore	Bipedal
Hollanda	Carnivore	Bipedal
Ichthyornis	Carnivore	Bipedal
Vegavis	Carnivore	Bipedal
Limenavis	Carnivore	Bipedal
Enaliornis	Carnivore	Bipedal
Baptornis_advenus	Carnivore	Bipedal
Baptornis_varneri	Carnivore	Bipedal
Parahesperornis	Carnivore	Bipedal
Hesperornis	Carnivore	Bipedal